

West

BROADCAST NEWS

VOL. NO. 87 FEBRUARY, 1956

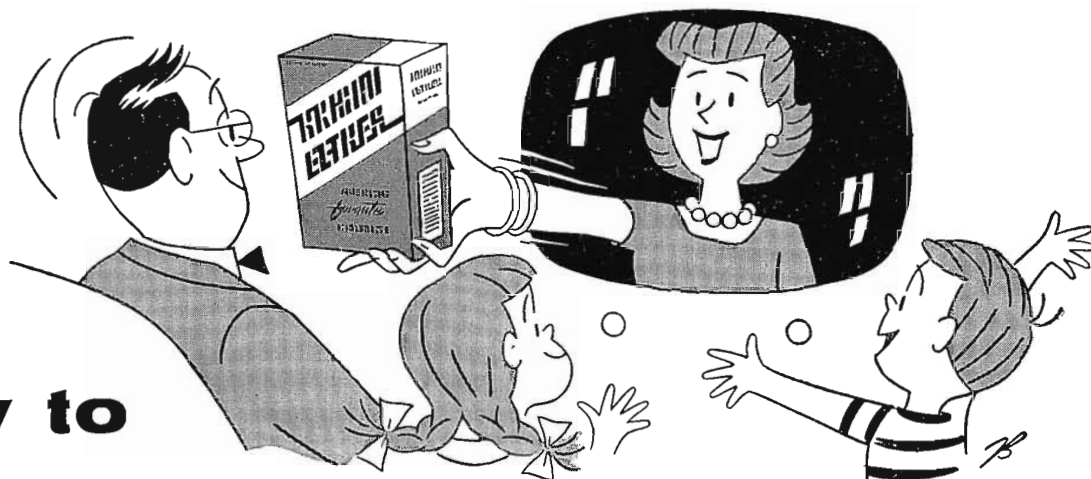



How to make your film programs produce "LIVE" picture interest

WHEN your film programs have the "snap" and realism characteristic of "live" pick-ups, you have a client benefit that sells itself and pays off handsomely. If you can achieve picture quality which will make it difficult for a television viewer to know whether the program coming into his home is "live" or "on film," you're in business!

It's possible to do just this with good black and white films—simply by replacing outmoded equipment.

Studio realism— highest picture quality

RCA's TK-21 Vidicon Film Camera is the answer. This improved equipment offers all the dimension associated with "live" programs, provides studio realism and highest picture quality. It's so life-like, the viewer gets the impression that the show is being presented in the studio just for him! Thus, the spot advertiser is offered the psychological advantage of "live" programming at the low cost of film. Competitively, this is your bread-and-butter business and its growth will be measured in direct proportion to its effectiveness.

A check of some of the more technical advantages shows why the TK-21 Film Camera is a station's best investment for extra profits . . .

"Live" picture sharpness

The TK-21 is the only film system with enough signal output to use aperture correction to bring picture detail up to maximum sharpness (detail resolution 100% at 350 lines) with a high signal to noise ratio.

"Live" picture contrast

The Vidicon tube is ideal for film reproduction. It has unexcelled contrast range

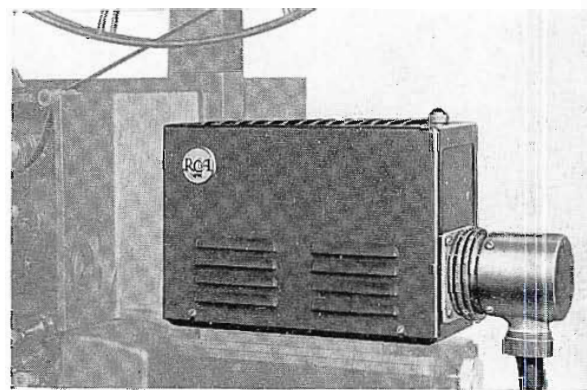

and assures realistic gray scale rendition over entire picture. This means you can get studio realism in your film pictures.

Edge-lighting, shading eliminated

The RCA Vidicon operates entirely without edge-lighting, electrical shading, or any other form of supplemental lighting. This camera virtually runs by itself. Used for finest quality reproduction of monochrome motion picture films or slides in a television system, the TK-21 may be mounted directly to projectors or multiplexed.

For complete information about the TK-21 Vidicon Film Camera, call your RCA Broadcast Sales Representative.

Ask
the Engineer
—he knows



**RADIO CORPORATION
of AMERICA**

ENGINEERING PRODUCTS DIVISION · CAMDEN, N.J.

In Canada: RCA VICTOR Company Limited, Montreal

Vol. No. 87

February, 1956

BROADCAST NEWS

published by

RADIO CORPORATION OF AMERICA
BROADCAST & TELEVISION EQUIPMENT DEPARTMENT
CAMDEN, NEW JERSEY

PRICE *In continental U.S.A. --- \$4.00 for 12 issues*
In other countries ----- \$5.00 for 12 issues

C O N T E N T S

NEW VHF STATION — WHIS-TV	<i>by P. T. Flanagan</i>	6
WHIS-TV THREE-HOP MICROWAVE SYSTEM	<i>by Paul A. Greenmeyer</i>	14
HOW TO MAKE LIVE COMMERCIALS USING RCA 3-V COLOR FILM CHAIN	<i>by S. L. Bendell, H. N. Kozanowski and T. J. Shipferling</i>	22
RECORD 4½ MILLION WATTS ERP PRODUCED IN UHF TV EXPERIMENT		26
NARTB ANNOUNCES THREE DAY ENGINEERING CONFERENCE		27
NEW EXPANDABLE CONSOLETTTE	<i>by E. J. Meehan</i>	28
RCA "AMPLIPHASE" FIFTY FOR WINS		31
"COLORIZING" OF WNBQ UNDERWAY		32
SCHOOL OF RADIO TECHNIQUE ADDS LIVE COLOR CAMERA TO TRAINING FACILITIES		34
TWO NEW AM TRANSMITTERS	<i>by E. J. Meehan and A. W. Powers</i>	40
WAAM-TV CONVERTS FROM IKE TO VIDICON	<i>by Ben Wolfe</i>	42
WDAS, PHILADELPHIA'S OLDEST INDEPENDENT GOES HIGHER POWER AND HIGH-FIDELITY		48
NEW SIGNAL HANDLING TECHNIQUES SIMPLIFY CONTROL OPERATIONS FOR COLOR TV	<i>by I. Bosinoff, A. C. Luther, F. W. Millsbaugh and H. M. Potter</i>	54

"RCA PIONEERED AND DEVELOPED COMPATIBLE COLOR TELEVISION"

Copyright 1956, Radio Corporation of America, Broadcast & Television Equipment Department, Camden, N. J.

PRINTED
IN
U.S.A.

the truth about...

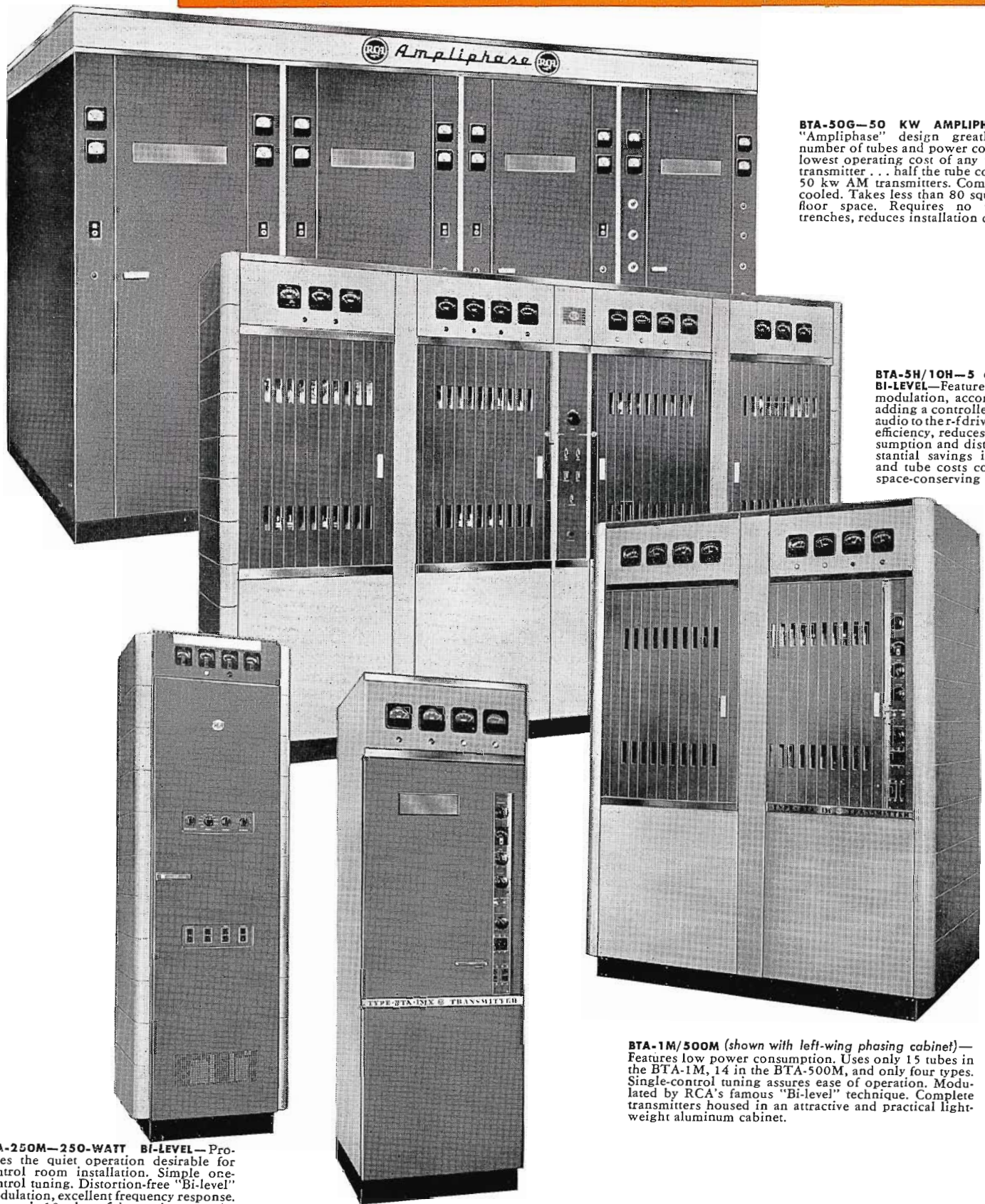

BTA-50G—50 KW AMPLIPHASE—New "Ampliphase" design greatly reduces number of tubes and power costs, assures lowest operating cost of any 50 kw AM transmitter . . . half the tube cost of older 50 kw AM transmitters. Completely air-cooled. Takes less than 80 square feet of floor space. Requires no under-floor trenches, reduces installation costs.

BTA-5H/10H—5 and 10 KW BI-LEVEL—Features "Bi-level" modulation, accomplished by adding a controlled amount of audio to the r-f driver, increases efficiency, reduces power consumption and distortion. Substantial savings in operating and tube costs combine with space-conserving design.

BTA-250M—250-WATT BI-LEVEL—Provides the quiet operation desirable for control room installation. Simple one-control tuning. Distortion-free "Bi-level" modulation, excellent frequency response. Uses only 10 tubes of three tube types. An ideal "economy package."

BTA-1M/500M (shown with left-wing phasing cabinet)—Features low power consumption. Uses only 15 tubes in the BTA-1M, 14 in the BTA-500M, and only four types. Single-control tuning assures ease of operation. Modulated by RCA's famous "Bi-level" technique. Complete transmitters housed in an attractive and practical light-weight aluminum cabinet.

BTA-1MX/500MX—Designed for high-fidelity operation, transmitters BTA-1MX (1KW) and BTA-500MX (500 watts) offer single-control tuning, desirable Bi-level modulation, low power consumption, fewer tubes and fewer tube types. Minimum floor space required . . . approximately 6 square feet.

REMOTE CONTROL EQUIPMENT—RCA Remote Control Equipment provides facilities to switch program lines, adjust plate or filament voltage, operate a line variac control on emergency transmitter, control Conelrad switching, operate power contactors and reset manual overload breakers, from any desired control point, regardless of transmitter design or power.

RCA AM transmitters

FOR 25 YEARS RCA broadcast transmitters have been widely acknowledged as *the* best. During this period they have been the transmitters most often chosen by those stations which wanted, and could afford, the very best. Thus they early became, and have remained, the standard to which all others are compared.

Unfortunately, some stations have believed that they could not afford such quality—no matter how much they wanted it. Today any station can “afford” one of these top-quality transmitters. In fact, it is hard for us to see how a station can afford *not* to buy one.

Why is this so? Simply because today RCA transmitters cost only a very little more than the lowest-priced (sometimes no more). And the small extra original cost (if any) is more than made up for by these two *facts*:

1. RCA transmitters are generally less expensive to operate. This is so because in almost every power class RCA transmitters either use less power, or have lower tube cost (in some cases both).

2. RCA transmitters almost always have higher resale value. This becomes very important when you go to higher power, or if you should decide to sell your station.

What is the moral? Simply this: don't jump to the conclusion you can't afford RCA. We believe you can, and we would like an opportunity to prove it. Call our nearest *AM Specialist* (see list). He will be glad to go over your situation with you, give you the benefit of his (and RCA's) broadcast equipment knowledge, and leave with you a complete and fair proposition. With such *facts* at hand you can make a correct decision. There's absolutely no obligation. You owe it to your station to find out. Act now!

See Your Nearest
Radio Broadcast Sales
Representative

ATLANTA 3, GA.
522 Forsyth Bldg., Lamar 7703

BOSTON 16, MASS.
200 Berkeley Street, Hubbard 2-1700

CAMDEN 2, N.J.
Front & Cooper Streets,
Woodlawn 3-8000

CHICAGO 54, Ill.
Delaware 7-0700 Merchandise
Mart Plaza, Room 1186

CLEVELAND 15, OHIO
1600 Keith Bldg., Cherry 1-3450

DALLAS 1, TEXAS
1907-11 McKinney Avenue,
Riverside 1371

DAYTON 2, OHIO
120 West Second Street,
Hemlock 5585

HOLLYWOOD 28, CALIF.
1560 N. Vine Street,
Hollywood 9-2154

KANSAS CITY 6, MO.
1006 Grand Avenue, Harrison 6480

NEW YORK 20, N.Y.
36 W. 49th Street, Judson 6-3800

SAN FRANCISCO 2, CALIF.
420 Taylor Street, Ordway 3-8027

SEATTLE 4, WASHINGTON
2250 First Avenue, South, Main 8350

WASHINGTON 6, D.C.
1625 K Street, N.W., District 7-1260

Typical AM Tower



RADIO CORPORATION of AMERICA
BROADCAST AND TELEVISION EQUIPMENT
CAMDEN, N. J.

Now! Live Color Commercials

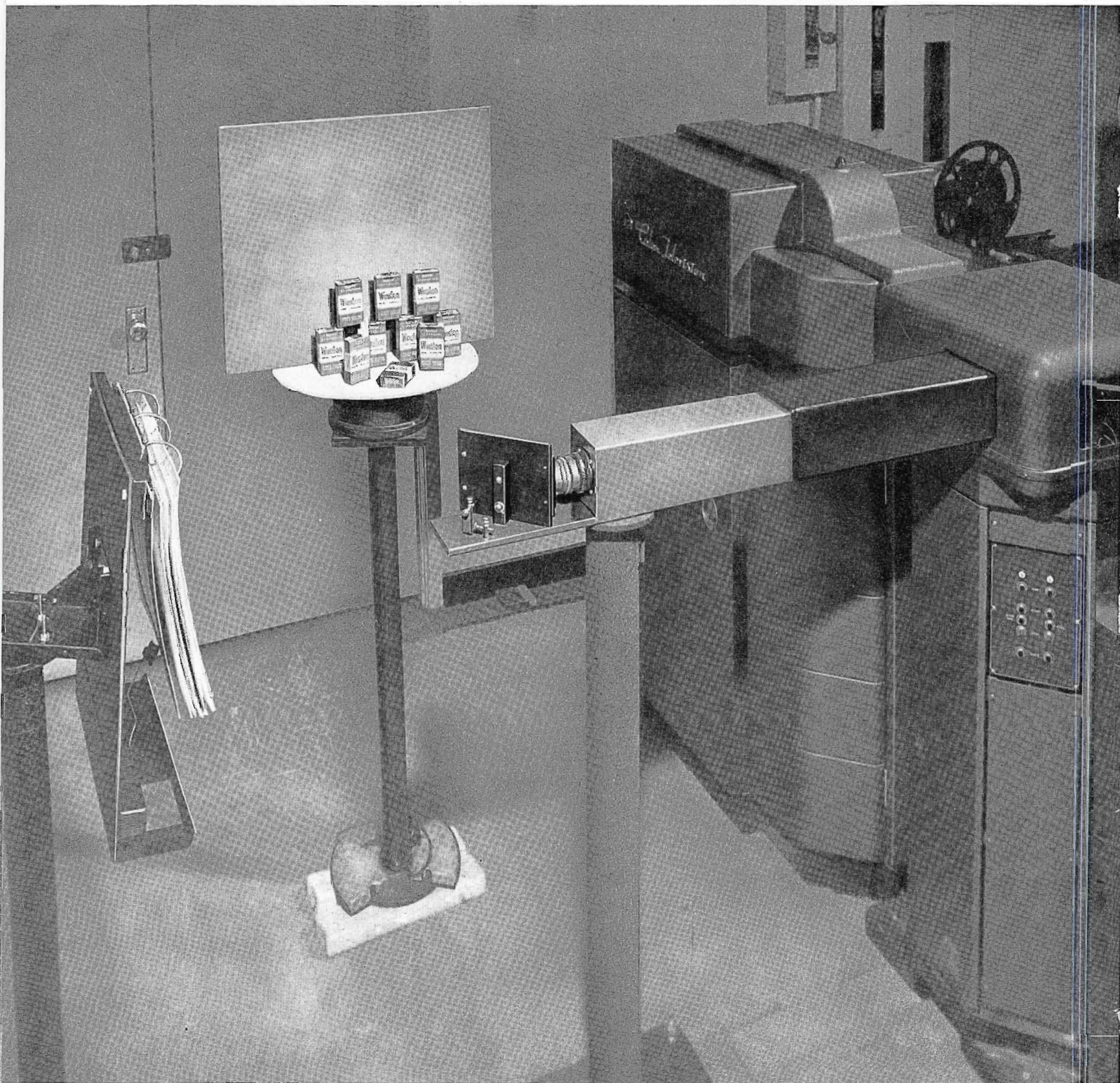

"3V" Color Film System as arranged for pickup of color opaques and live action commercials.

RCA Pioneered and Developed Compatible Color Television

with your RCA "3V"!

Simple lens system added to RCA "3V" Film Camera picks up live-action color commercials...and color opaques of all kinds

NOW you can go to "live" color in the least expensive way imaginable. RCA engineers have worked out an extension lens system which can be used with any RCA "3V" Camera to pick up all kinds of product displays . . . live . . . in action . . . in highest quality color. And the same system can be used for televising color opaques in the simplest possible manner.

Products to be colorcast are set up on a small, fixed stage (as shown on opposite page). Any type of action which can be carried out in a limited area is practical. You can turn products around, upside down, etc. . . . show liquids foaming . . . real bottle pouring . . . use of tools . . . appliances in operation . . . wind-up toys in action . . . all kinds of animation.

Color opaques can be artwork, charts, maps, diagrams, magazine pages, comic strips. They can be mounted on an easel, on a flip-over stand (as shown at right), or held in the hand. You can use artwork or catalog illustrations and thus avoid making slides. Color rendition is nearly perfect; there are no density problems as with color slides.

Both products and opaques are televised in the open . . . in fully lighted rooms. No need for light covers or strobe lights. Pictures have high resolution inherent in vidicon type camera. Picture quality and color is equal in every way to that attained with studio type color cameras.

Development of a push-button operated 4-input multiplexer makes it possible to use an RCA "3V" camera for televising "live" color commercials, color opaques, color transparencies, color slides and color films. Such an arrangement provides maximum usefulness of equipment—gets you into color in the fastest and least expensive way.

And remember, the RCA "3V" Film Camera System is the system which most broadcast engineers believe to be the best.

For complete technical information on the new RCA "3V" Color Film System, call your RCA Broadcast Sales Representative. In Canada: write RCA VICTOR Company Ltd., Montreal.

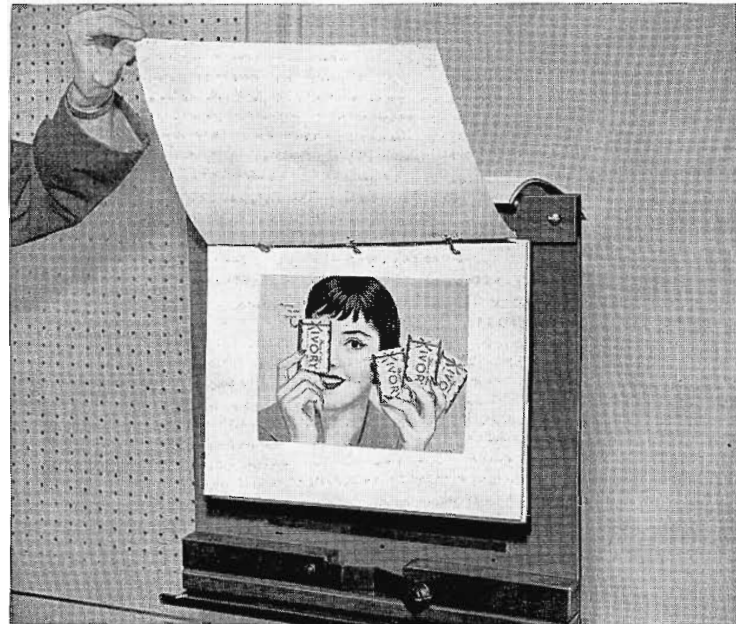

Color opaques in series, at a flip of the wrist.



Live color commercials with a minimum of props, showing hands, etc.



RADIO CORPORATION of AMERICA
BROADCAST EQUIPMENT, CAMDEN, N. J.



NEW VHF STATION

WHIS-TV

BLUEFIELD, W. VA.

by P. T. FLANAGAN
Administrative Director, Radio and Television

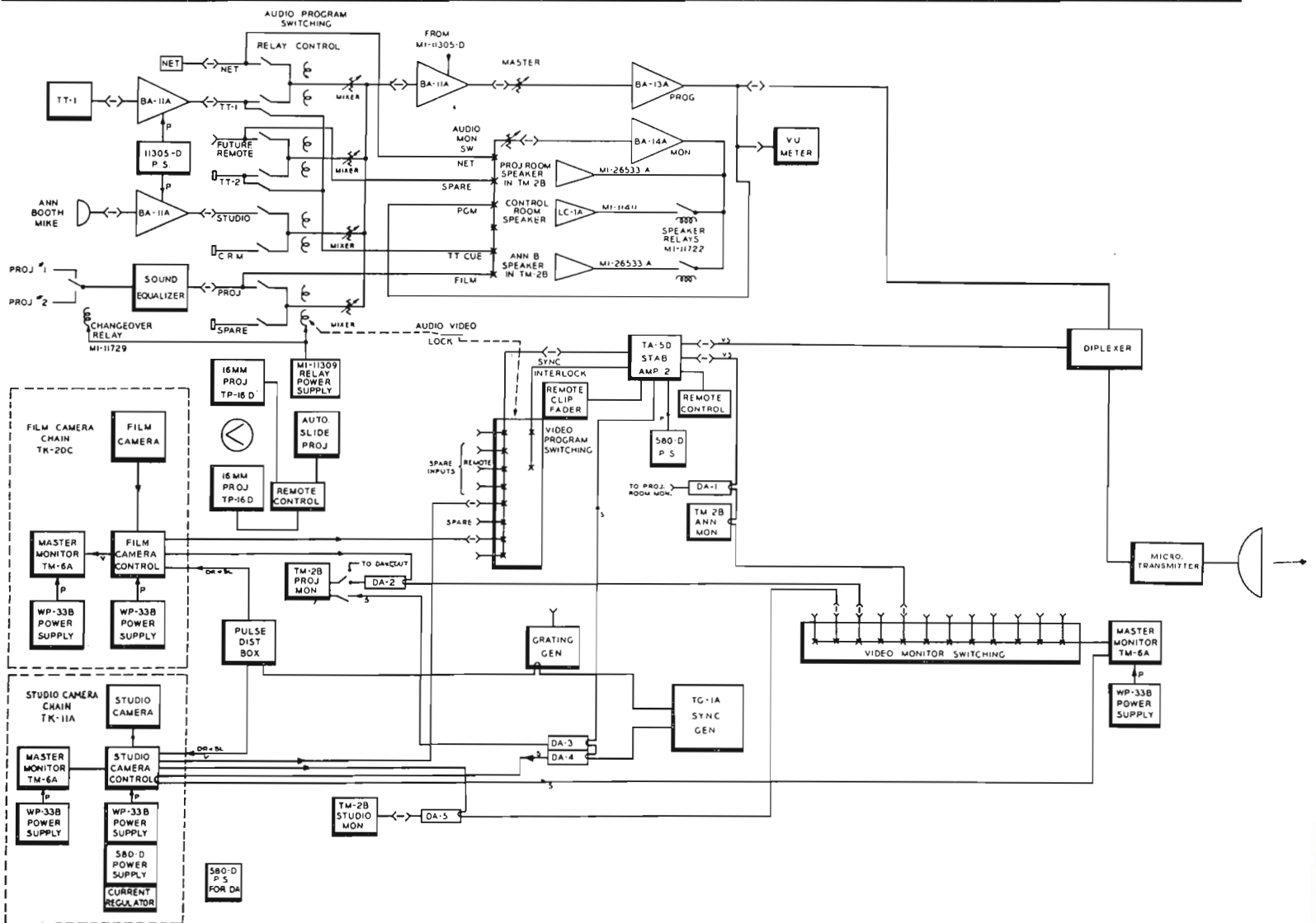

When they spilled "water" from the battery on their father's beautiful living room rug, young Jim and Hugh Shott, Jr., incurred more than the Senator's momentary displeasure. They also put holes into their dream of broadcasting election returns that night in 1922, as well as their immediate plans for building a permanent radio station. Not too many years after, however, in 1928, they established the first radio broadcasting station in Bluefield, West Virginia. Today, it is one of the town's most popular stations and the "boys", now two of the most influential citizens of Bluefield, have succeeded in bringing a VHF station of 50 KW power to their thriving community.

When allocations were resumed after the freeze, Bluefield had been left out of the picture so far as VHF service is concerned since only a UHF station, which would have operated on channel 43, was assigned.

Management of the Daily Telegraph Printing Company, and owners of the radio station WHIS, of which Jim H. Shott is president, and Hugh I. Shott, vice president and general manager, felt that a UHF station was not suitable for the mountainous terrain.

It was believed that only a VHF station could serve the best interests of the area, and it was pointed out that Charleston, Huntington, Wheeling and other nearby cities had been allocated VHF stations and, furthermore, that two were assigned to Roanoke.

Accordingly the management of the new station made a thorough study of the situation and the allocations, then made a proposal to the FCC that ultimately resulted in the allocation of VHF channel 6 in Bluefield. It took a considerable amount of time and effort to get the change made.

First, it was necessary to get the zone line between TV zones 1 and 2 changed. The original line of separation put Bluefield into zone 2. WHIS management petitioned the FCC to change the line to conform with the southern boundary of West Virginia. The petition was finally granted after many trips to Washington and after a number of hearings were held.

The FCC was then petitioned to move channel 6 from nearby Beckley to Bluefield and to give Beckley in its place channel 4, both of which changes would fit the FCC allocation pattern. After a period of litigation which involved the neighboring cities of Oak Hill and Beckley, as well as High Point, North Carolina, and other towns, this petition was also granted.

The construction permit was granted to WHIS-TV October, 1954, and the station went on the air for testing July 31, 1955.

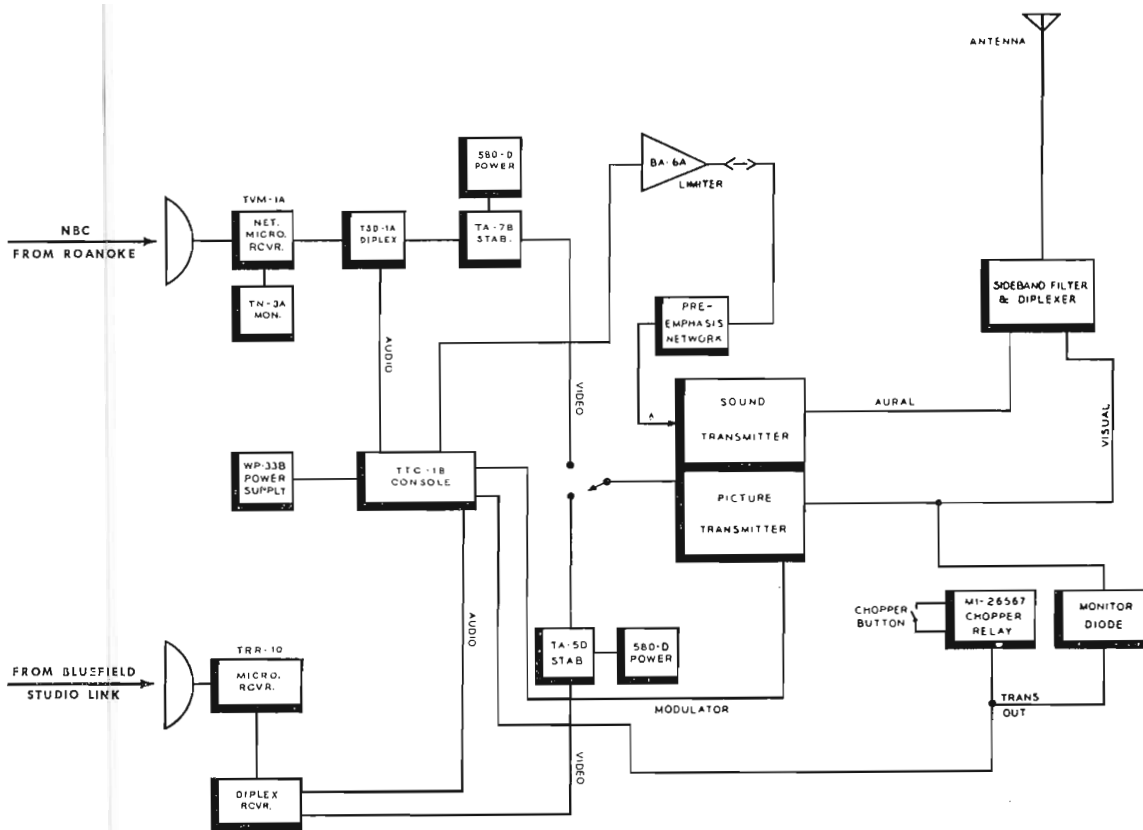

FIG. 1. Block diagram showing studio and transmitter equipment with connecting microwave link.

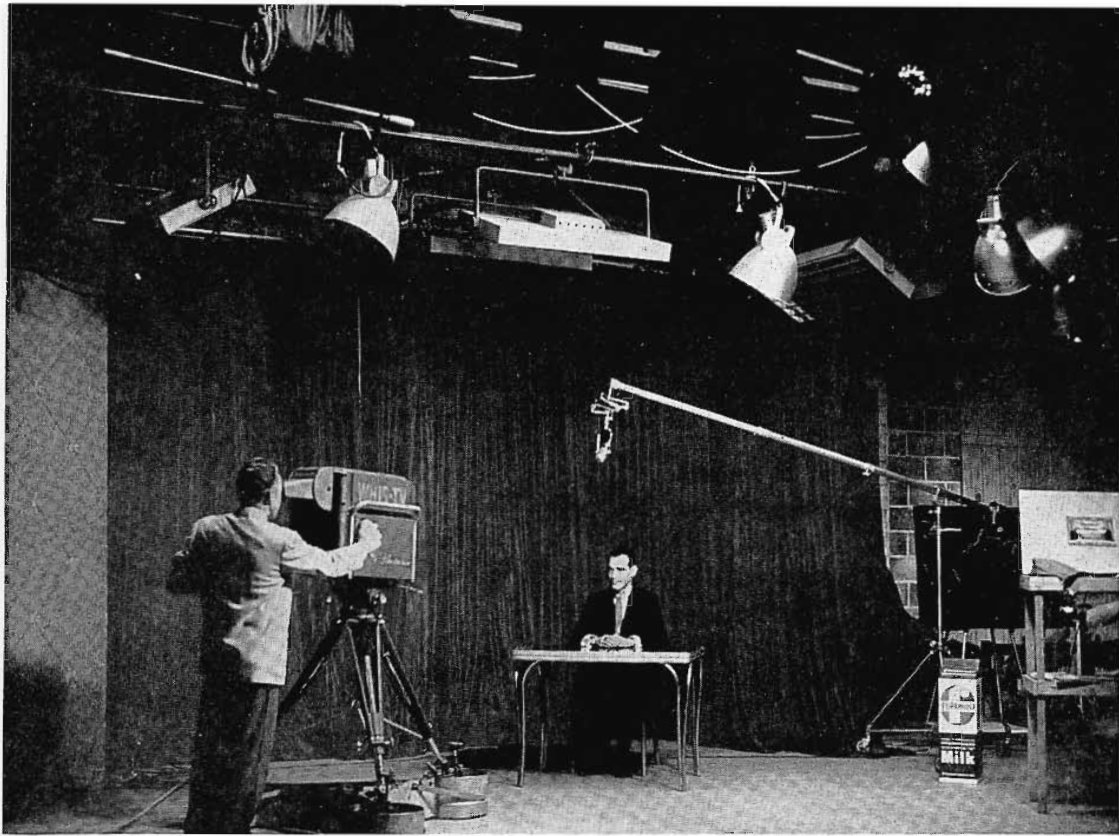

FIG. 2. Part of TV studio total size of which is approximately 30 x 40 feet.

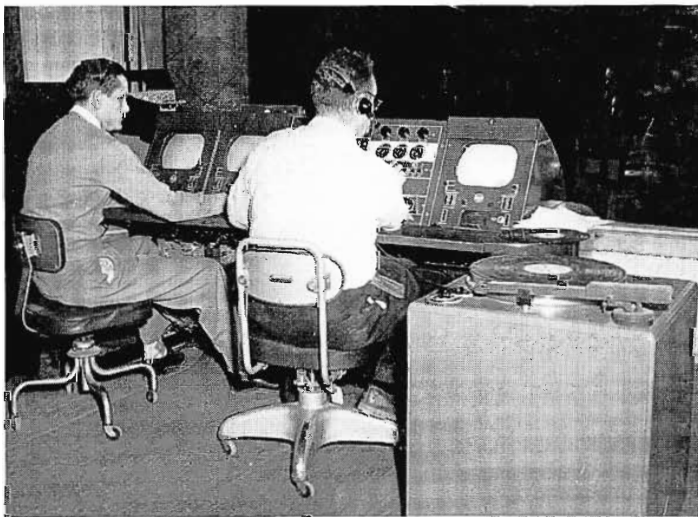

FIG. 3. TV studio control. Left: video operator. Right: combination director and audio operator.

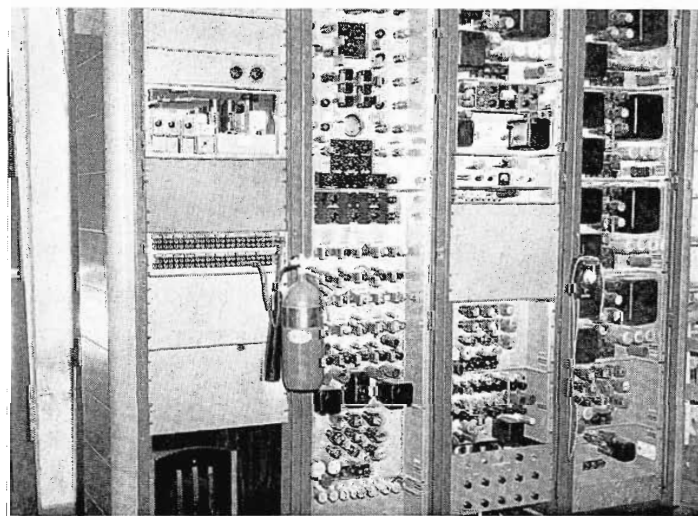

FIG. 4. Equipment racks in studio control room.

Studio Location

The station has two floors in the Municipal Building in downtown Bluefield where new studios for both AM and TV operation have been built. The lower level contains reception area, AM and TV studios, film room, general offices and viewing room. The upper level contains the art department, engineering lab and workshop, viewing room and engineering store room. Figure 18 shows layout and how it is designed for smooth flow of traffic and for operating convenience.

Studio "A" for TV operation is a concrete floored area approximately 30 by 60 feet. At one end are windows of the TV control room while the other end opens into a large property room. This, in turn, opens onto a ramp that runs down to street level. By means of this ramp equipment as large as a household moving van (tractor-trailer combination) can be driven up to the property room.

One RCA Type TK-11A Studio Camera is employed at the present time. Only a few local shows are programmed and these usually require but a few participants. As time goes on and programming increases, it is planned to add another camera.

Both sides of Studio "A" accommodate permanent sets (see Figs. 18 and 19). In addition one side has three windows for client and VIP viewing in three separate viewing areas and on two different levels.

Studio walls consist of cinder block partitions. Fixed set backgrounds used for spots, news, weather, etc., have been permanently attached to the walls. These can be covered by means of a travelling drape arrangement so that temporary sets for special shows can be put up.

The TV control room, 16 by 19 feet in size, is located several feet higher than Studio "A", hence the director has a most convenient base of operation. It contains an RCA Type TC-4A Audio-Video Switching Console. Three TM-2B Utility Monitors and one TM-6A Master Monitor are employed. Microwave control equipment for the STL is also located here. The control equipment is located directly in front of the large viewing window. Two men

operate the controls: One acts as video control and the other as combination director and audio control man.

A small announce booth is located just off the TV control room. It contains utility monitor, microphone and speaker.

Studio "B" is the AM studio which is approximately 20 by 30 feet in area. Along one side is located the viewing window of the AM control room. This studio is also designed to serve as an auxiliary TV studio. The door openings have a special "boot" at the floor which can be removed to allow a TV camera dolly access to the studio (see Fig. 5).

The TV film room is large, 22 by 19 feet, and is conveniently located adjacent to the TV control room. It is equipped with a complete RCA film system, consisting of TK-20 Iconoscope Film Camera operating into a TP-9 Multiplexer with two TP-16 Motion Picture Film Projectors and a Gray TP-3 Dual Disc Slide Projector.

An extensive film library and complete film editing facilities are accommodated in the same area.

Programming

WHIS-TV is on the air from 1 p.m. to midnight each day. Top NBC shows and local entertainment have started off WHIS telecasting. One of the local programs is a 15-minute sports show conducted by Sunset News sports editor Bill Elliott, "Sports Highlights", 6:15 p.m. Monday through Friday. Another local program is the "Jack Call Show" which is a series of Saturday evening organ recitals. For children, two daily local shows: "Circle 6 Ranch" features Wild Bill Hickok and "Serial Time" with Scoop and Snoop, popular announcers and entertainers of the WHIS-TV staff. Fifteen minutes of local and national news and weather are featured daily also. In addition a daily film show "Arm Chair Playhouse", presents top screen dramas.

Within 90 days it is expected to have full day programming. Color network operating equipment and color test equipment are being installed so that NBC color programs may be broadcast.



FIG. 5. Note novel construction of doorway where door jam meets floor in order to permit passage of camera dolly. Removable "boot" is shown at lower left. This is put back into position after camera has passed through.

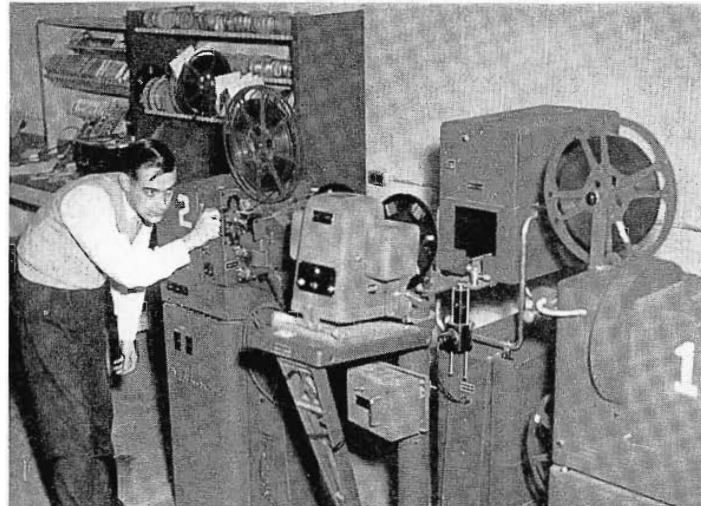

FIG. 6. The film room is equipped with two RCA 16mm TV film projectors, 35mm slide projector and RCA film camera.

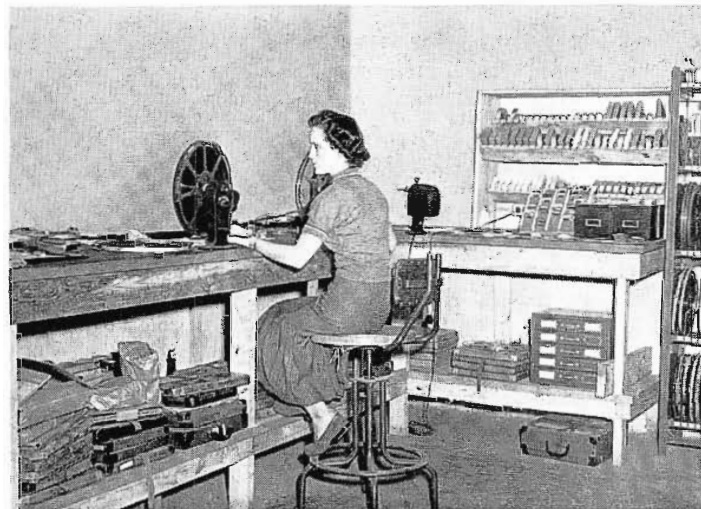

FIG. 7. Film library and editing facilities complete the film room arrangement.

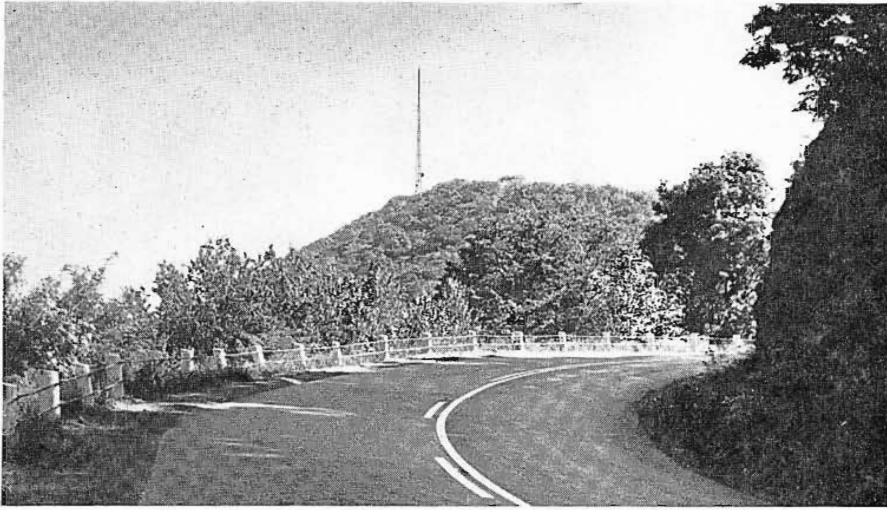

FIG. 8. WHIS-TV tower is located atop East River Mountain, West Virginia.

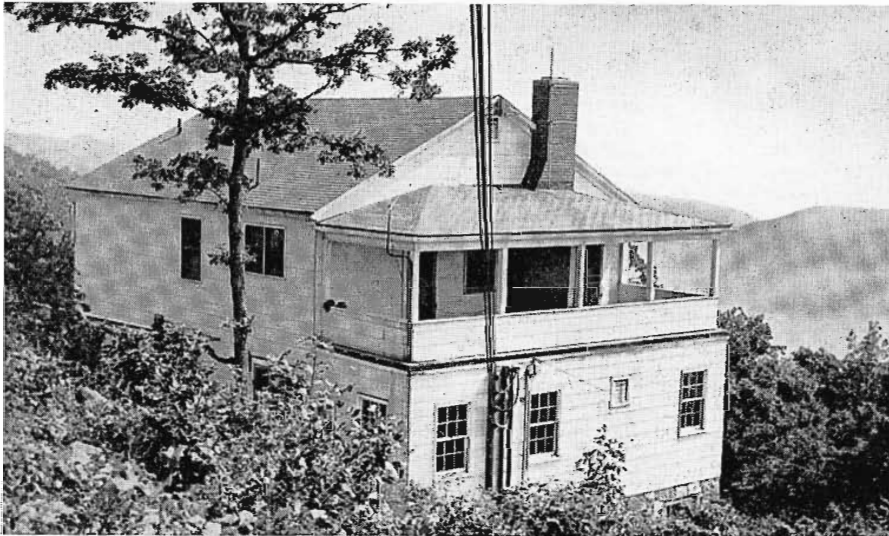

FIG. 9. Transmitter is housed in building which also provides living quarters for transmitter engineer and family on second floor.

The Transmitter

WHIS-TV broadcasts on channel 6, using a 10 KW RCA Transmitter Type TT-10AL with Type TTC-1B Control Console and 6-bay antenna. Since the transmitter is located two miles from the studio, an STL link using RCA Type TRR-1B Microwave Relay equipment is used to connect transmitter and studio. Four-foot reflectors are used at the terminals.

The transmitter is housed in a 2½-story building, high on the side of East River Mountain, more than a thousand feet above and two miles from the city of Bluefield. The stone and asbestos shingle structure was designed and especially built for broadcast use. In addition to a commodious transmitter and control room, and maintenance areas, the building has a large apartment on the second floor that serves as living quarters for the transmitter engineer and his family.

FIG. 10. RCA 10 KW TT-10AL transmitter with TTC-1B control console.

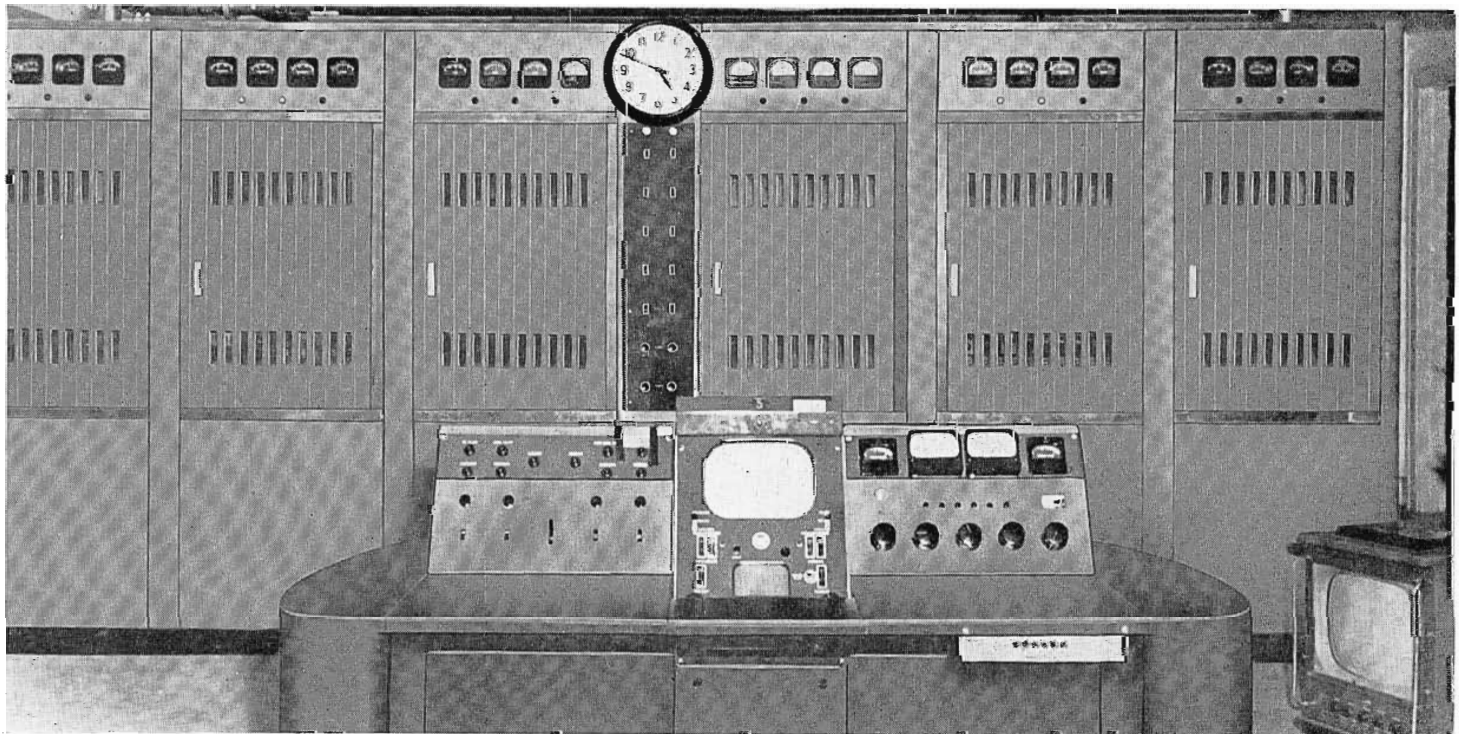

The antenna tower is located partly down the side of the mountain rather than at the ideal location, because the state boundary line runs across the top. In order to be in West Virginia, its legal location, the WHIS-TV tower had to descend 43 feet to find a suitable foundation. Even so the tower and antenna rise 100 feet above the mountain, which has an elevation of 3750 feet, hence the total height is 3850 feet above sea level.

The Ideco tower is 100 feet high and the RCA antenna is 82 feet high. The antenna is an RCA Type TF-6BM 6-bay Superturnstile. Microwave "dishes" for both the 3-hop NBC network connection to Roanoke, Va., and the STL link, are also mounted on this tower.

The station owns 11 acres of ground in Virginia and West Virginia at the top of this mountain. A private road which is rather rough and rocky throughout its 1400-foot length leads from the highway to the transmitter.

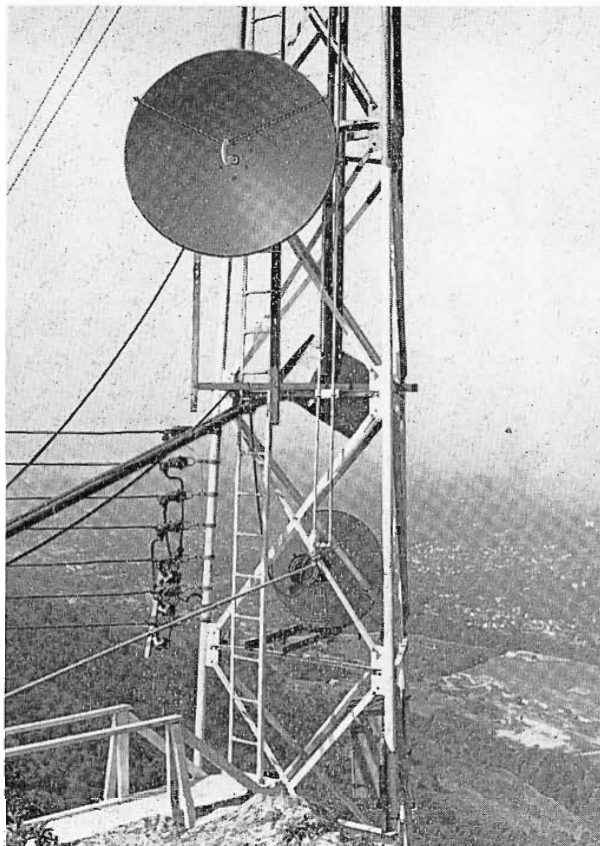

FIG. 12. Transmitter tower showing microwave dish of 3-hop system (at top) and rear of STL dish (beneath).

FIG. 11. Racks in transmitter room contain microwave terminations, frequency monitor, power supplies and other equipment.

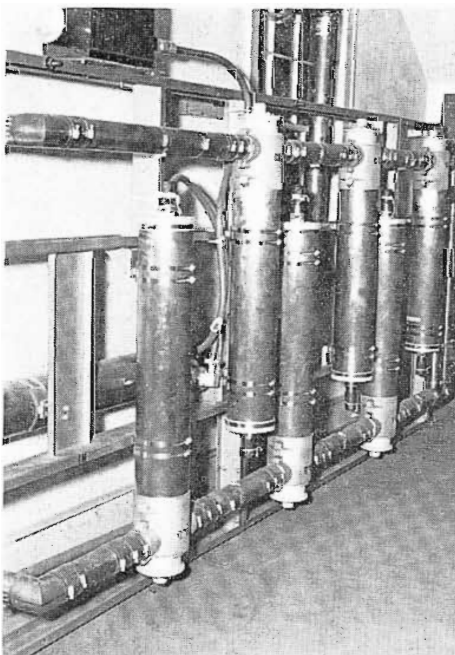
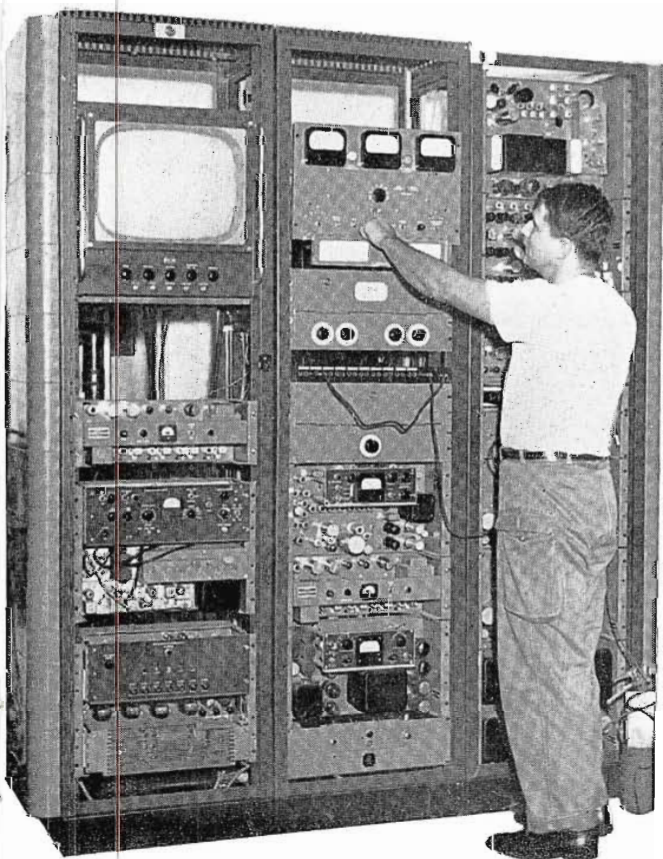

FIG. 13. Vestigial side band filter is installed in corridor adjacent to transmitter room.

FIG. 14. Tower is 100 feet high and supports an RCA 6-bay Superturnstile 82 foot antenna.



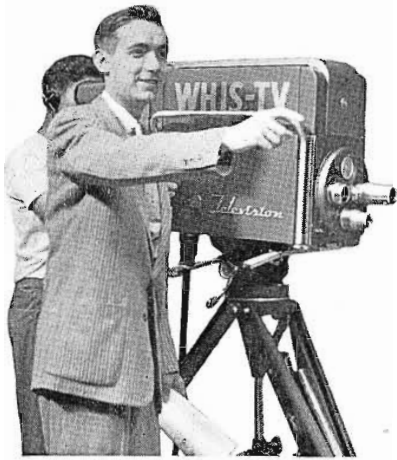

FIG. 15. Elvin Feltner, Production Director, WHIS-TV, conducts rehearsal.

Personnel

General Manager, Hugh Shott, Jr.; Administrative and Engineering Director, P. T. Flanagan; Chief Engineer, John Byers; Commercial Manager, John C. Shott; Production Director, Elvin Feltner; Program Director, O. C. Young; Transmitter Operator-Engineers, Paul Osburn and Kenneth Dick.

The administrative director has a staff of twenty-nine people to run both stations. Ten people run the TV operation at the present time. There are two cameramen but they and everyone else have more than one job to do.

Background

WHIS is named for Hugh Ike Shott, Sr., former congressman (1928-32) and later Senator (1941-42) representing the State of West Virginia. Hugh Ike Shott, Sr., was publisher of both local newspapers. The *Sunset News* is a local evening, while the *Bluefield Daily Telegraph* is a regional paper published mornings and Sunday. Each paper has its own staff of writers and editors, who express diverse political viewpoints. Both, however, use the same composing and printing facilities. Each has its own separate format and type face so each presents a different physical appearance.

The Shott family carries on the tradition of pioneering in mass communication

with the inauguration of the newly erected TV station. Both sons, Jim and Hugh, Jr., are prominent in carrying on the activities of the radio and TV stations. One of the grandsons, John C. Shott, is commercial manager, handling both radio and TV time sales. Another grandson, Ned Shott, is business manager of both newspapers and radio and TV stations.

Plans for the future call first for full day programming and then for addition of color film and live color facilities.

Bluefield Prospectus

The town, partly in Virginia and partly in West Virginia, once was solely a thriving bituminous coal community, but has since successfully adapted its industrial format to keep pace with progress. New industries have been brought to the city by an enterprising group of citizens. These have banded together to form the Bluefield Area Development Corporation. As a result, today the town is fully employed and growing. The coal industry, although employing fewer workers, is mechanized for efficient operation and is operating at a profit to all concerned. Bringing television to this expanding and progressive community is a natural and necessary part of its continuing development. Television will help to make Bluefield as much a part of the heritage and culture which is America as Bluefield has already shown itself to be.



FIG. 16. John C. Shott is Commercial Manager of Station WHIS-TV.

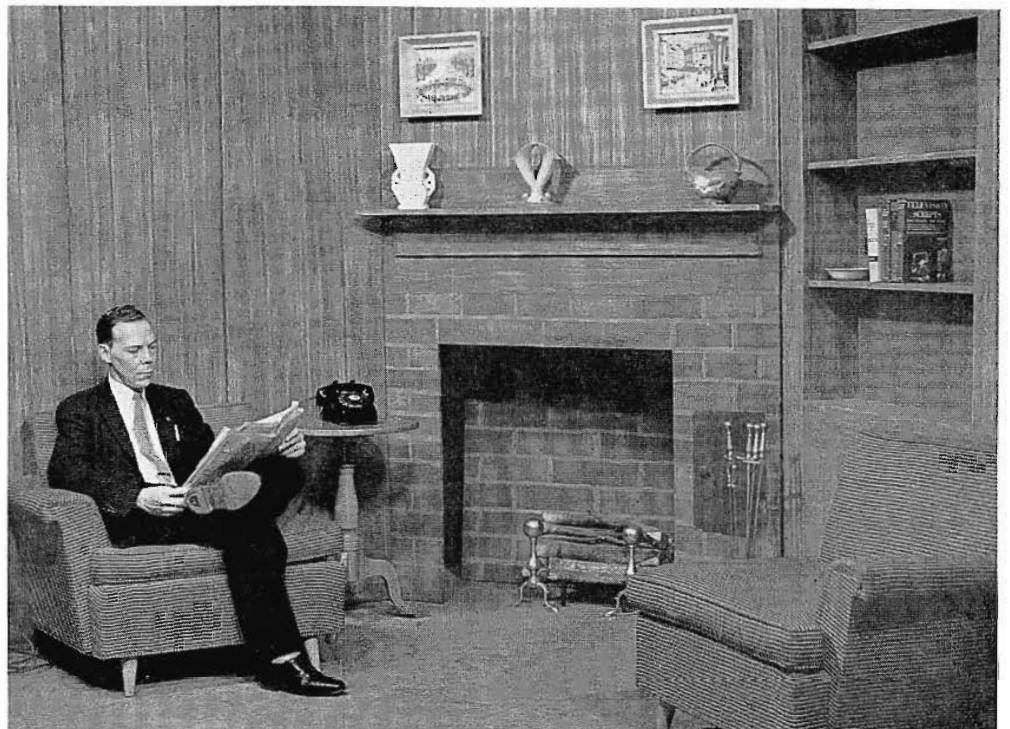
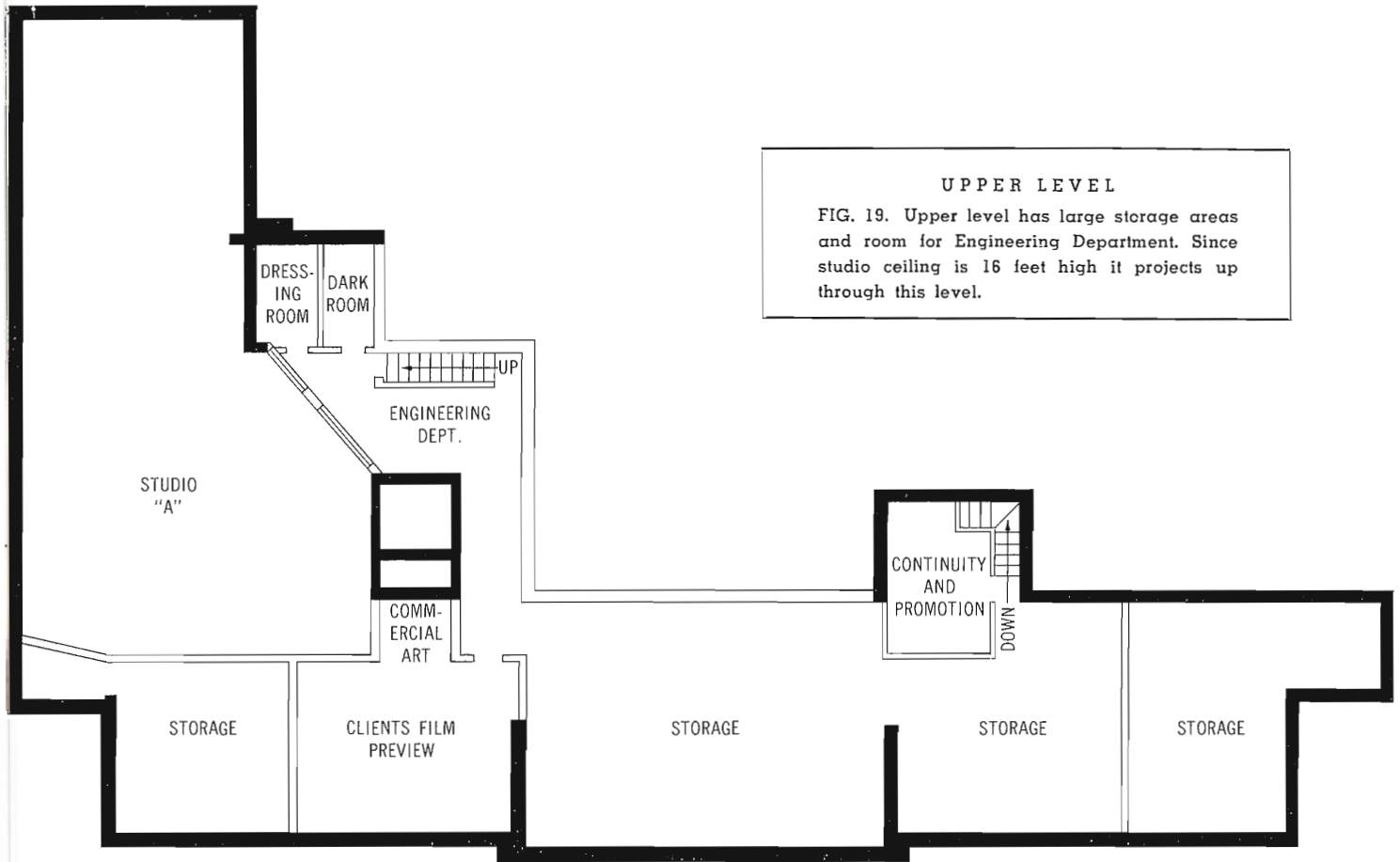
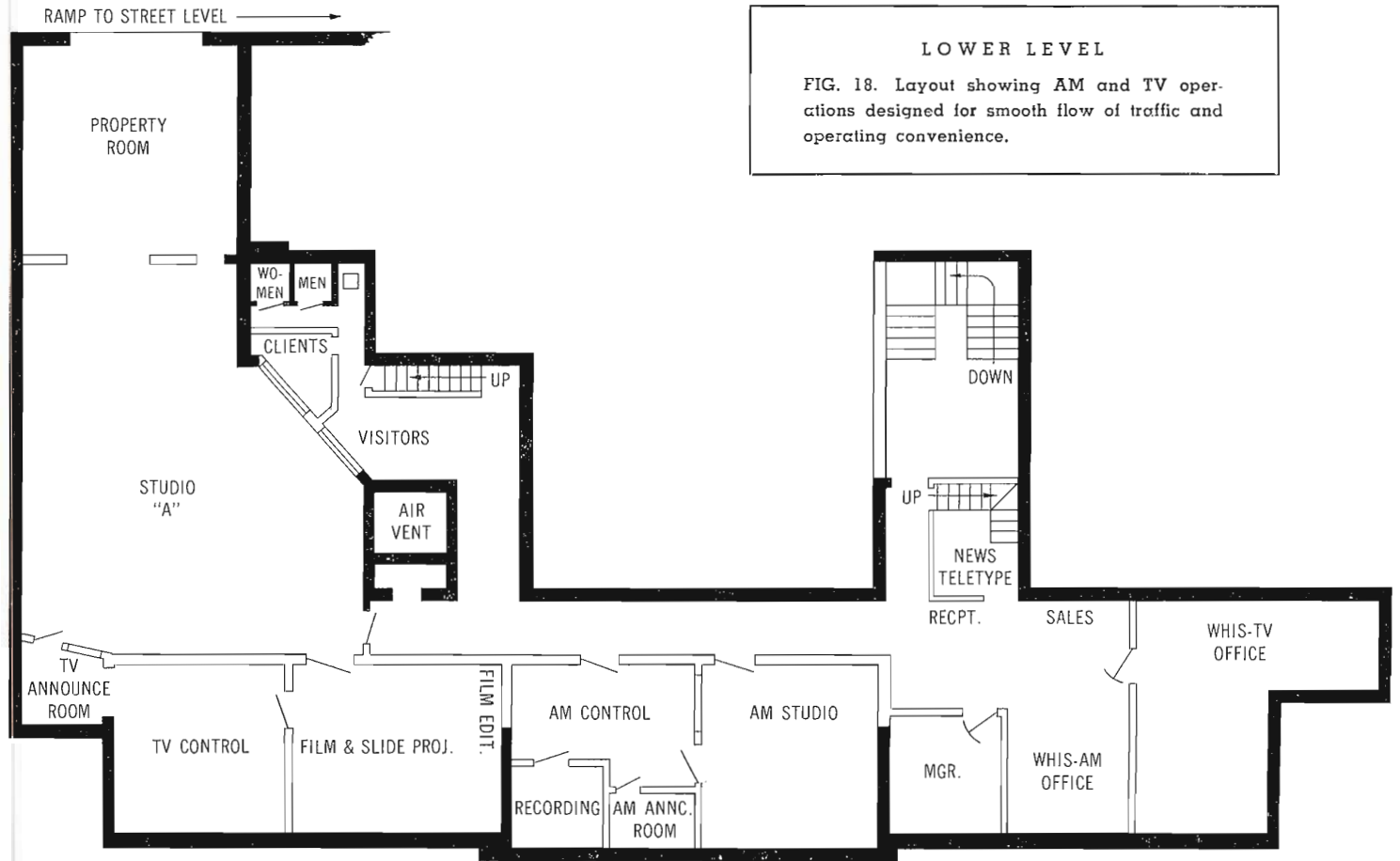

FIG. 17. Typical fixed set used in studio of WHIS-TV. This can be covered by means of a traveling drape so that temporary sets for special shows can be set up.



UPPER LEVEL
 FIG. 19. Upper level has large storage areas and room for Engineering Department. Since studio ceiling is 16 feet high it projects up through this level.



LOWER LEVEL
 FIG. 18. Layout showing AM and TV operations designed for smooth flow of traffic and operating convenience.

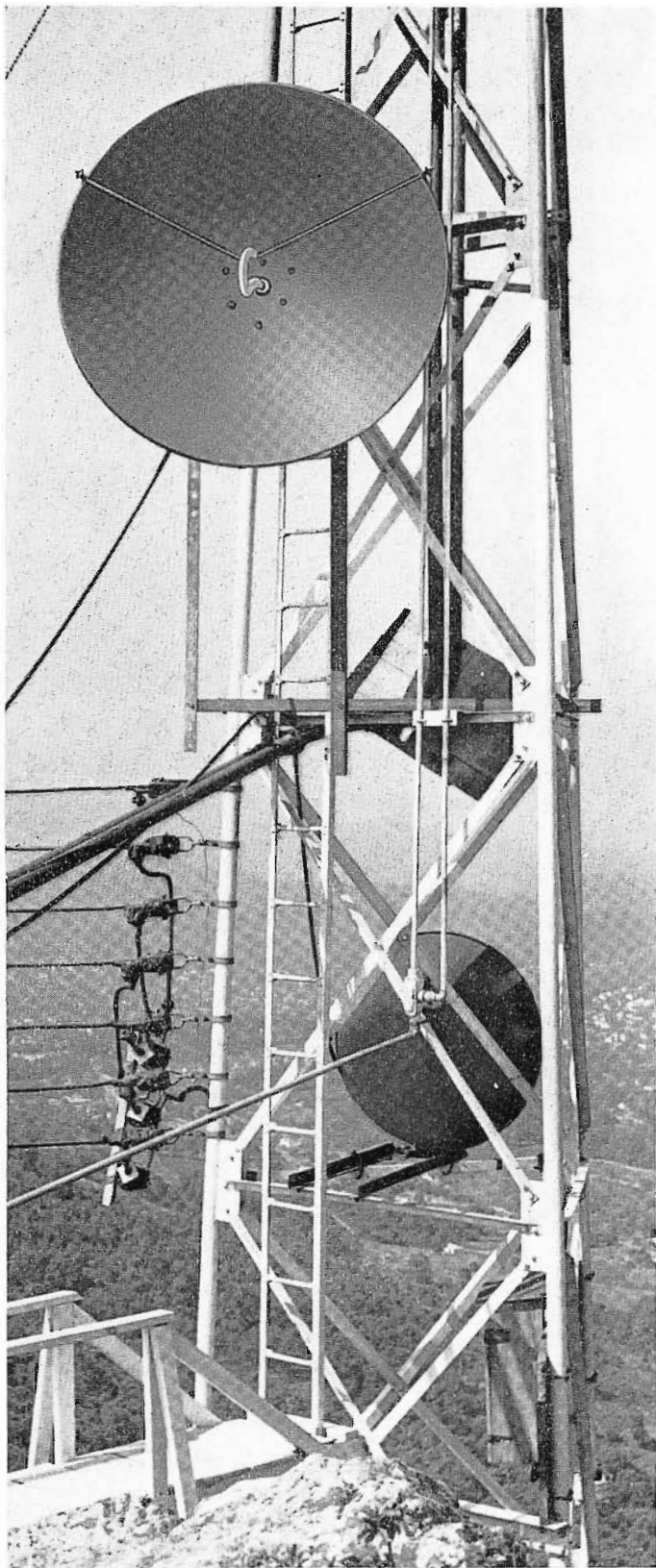
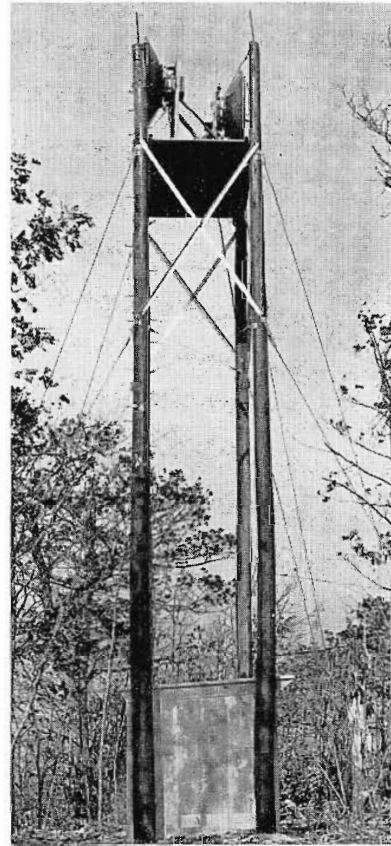
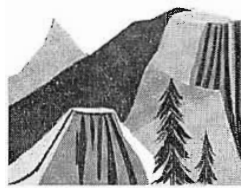

FIG. 1. Terminal of WHIS-TV Microwave system at East River Mountain, W. Virginia.

FIG. 2. Microwave relay station at Dismal Peak, Virginia.



WHIS-TV

By **PAUL A. GREENMEYER***

Since 1928, WHIS has been an outstanding radio station in the town of Bluefield, West Virginia, and in August 1955, its management inaugurated the opening of WHIS-TV, the town's first and only television station, but immediately, a large problem arose: Since there were no network common carrier facilities, how was the new station to supply sufficient programming to justify its existence? When approached upon the subject, AT&T indicated there were no plans afoot to put in a common carrier connection between these cities. Thereupon, with typical resourcefulness, Jim and Hugh Shott, president and

* Managing Editor, BROADCAST NEWS.

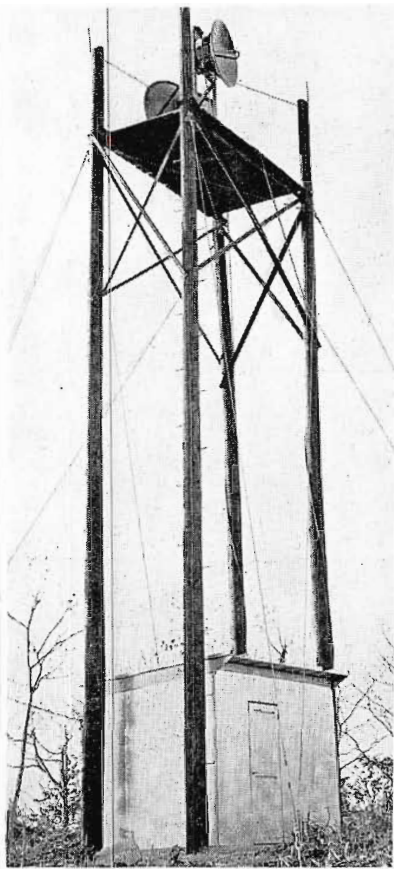

FIG. 3. Microwave relay station, Poor Mountain, Virginia.



FIG. 4. Microwave terminal at Roanoke, Virginia.

Three-Hop Microwave System

general manager of WHIS-TV respectively, decided to install their own microwave relay system to bring NBC programs from Roanoke, Virginia, a distance of some 70 air line miles.

Description of System

The microwave relay is a one-way system that originates in Roanoke and pro-

ceeds to Bluefield via two intermediate relay points. The first relay site is 15 air miles west of Roanoke at Poor Mountain. The second relay site is 38.8 air miles from Poor Mountain at Dismal Peak. Finally, the system terminates 20 miles from Dismal Peak at East River Mountain, which is the location of the WHIS-TV transmitter.

Microwave Equipment

The WHIS-TV network feed employs the new RCA Type TVM-1A Microwave Relay equipment, which is designed for monochrome and color operation. It generates one watt of transmitter power (10,000 watts ERP with a 6-foot dish), has a sound channel, and features transmitter AFC and transmitter picture moni-

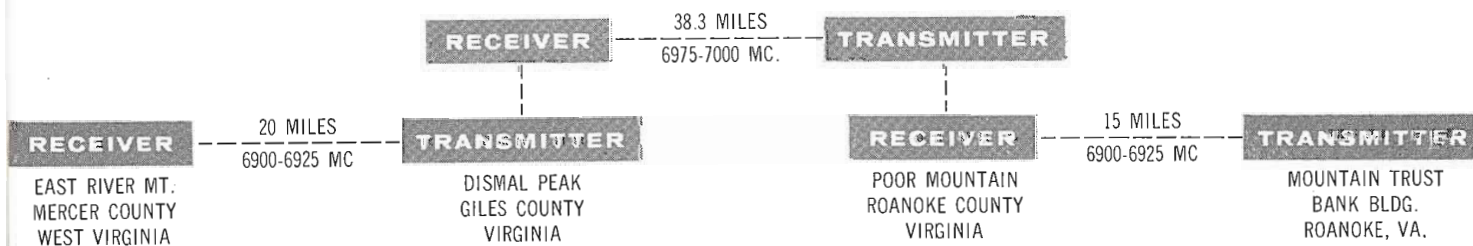

FIG. 5. Diagram of WHIS-TV Microwave system.

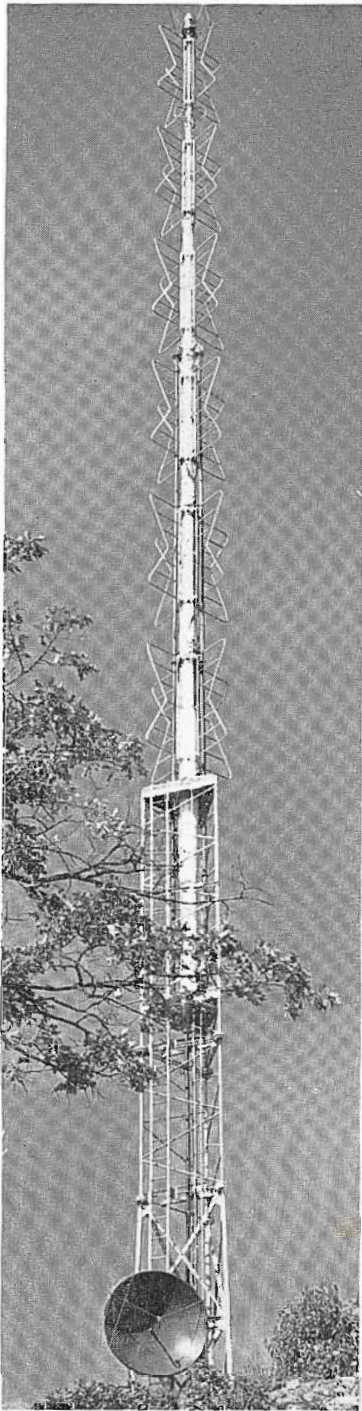

FIG. 6. WHIS-TV tower at East River Mountain, West Virginia showing 6 foot parabolic microwave antenna 15 feet above top of mountain.



FIG. 7. Side view of microwave installation at Roanoke terminal showing 4 foot parabolic reflector with head end transmitting equipment and angle iron supporting frame.

toring. Unitized construction is utilized for ease of servicing. Standard RCA equipment was employed. No modifications thereof were necessary.

Equipment Requirements

Since the system is a one-way arrangement, it was only necessary to have one complete receiver and one complete transmitter assembly at each relay station. The originating point required a transmitter only, while the terminal required a receiver only. Thus, the entire system called for the use of three complete receiver units and three complete transmitter units.

A sound diplexer modulator is provided at the network terminal point in Roanoke. A sound diplexer demodulator is similarly provided at the final receiving point to provide the required audio signal.

Antennas

At the originating point and at the first receiver 4-foot parabolic antennas are used. At all other sites 6-foot parabolic reflectors are used. The reflectors are all mounted

sufficiently high to clear local obstructions. The greatest distance that any reflector is mounted above ground is approximately 40 feet.

At the broadcast transmitter location on East River Mountain the microwave receiving parabola is attached to the 100-foot transmitter antenna tower, at a point 58 feet up from the bottom, which puts the parabola 15 feet above the top of the mountain.

The transmitter and receiver R-F sections are attached to the reflectors and are easily accessible at all locations. The majority of the electronic equipment at each station is located in a small building at the base of each tower. All adjustments and tests are now made on the ground after the initial system installation.

An extremely desirable feature of the system from the servicing standpoint is the facility for monitoring the video signal transmitted from each relay station at the station itself. This is an exclusive system of "off-air" monitoring.

Planning the System

Patrick ("Pat") Flanagan, Engineering and Administrative Director of WHIS Radio and Television, was handed the assignment to plan, install and operate the microwave system. Layout of the microwave paths and choosing the relay sites was a new and rather unusual job. Also, it was not an easy job because of the mountainous terrain. The success of the entire operation would hinge upon the choice of a path that would prove to be unobstructed.

The first step was to investigate a path which had already been surveyed from Roanoke to Bluefield by the local electric power company. Flanagan found, however, that a portion of this path was not suitable for his purpose because of an obstruction that appeared when he endeavored to lay out a direct route from the relay site at Butt Mountain to Bluefield, see Fig. 8. (The power company's path led to Bluefield from Butt Mountain via an additional link beyond the town.) In order to clear the obstacle, Flanagan estimated that he would

have to build a 250-foot tower, light it, and use a passive reflector on the tower. All of this meant considerably more time and expense in the way of construction and maintenance.

After more study of geodetic maps a second route was selected for the final link to Bluefield. A site known as Dismal Peak, some 20 miles southwest of Butt Mountain, was chosen. This path was sufficiently far removed from the first to completely eliminate the obstacle. In addition the second route turned out to be a more direct path (see Fig. 8).

The routes were set up first on U. S. geodetic maps and then in the field. Compass, binoculars, and mirrors were used to locate lines from one site to another. Voice circuits were established at the various sites through local switchboards and temporary wire lines strung to the top of mountain peaks. Thus the engineers could talk back and forth with each other while attempting to establish line-of-sight paths.

FIG. 8. Map showing route of WHIS-TV microwave system.

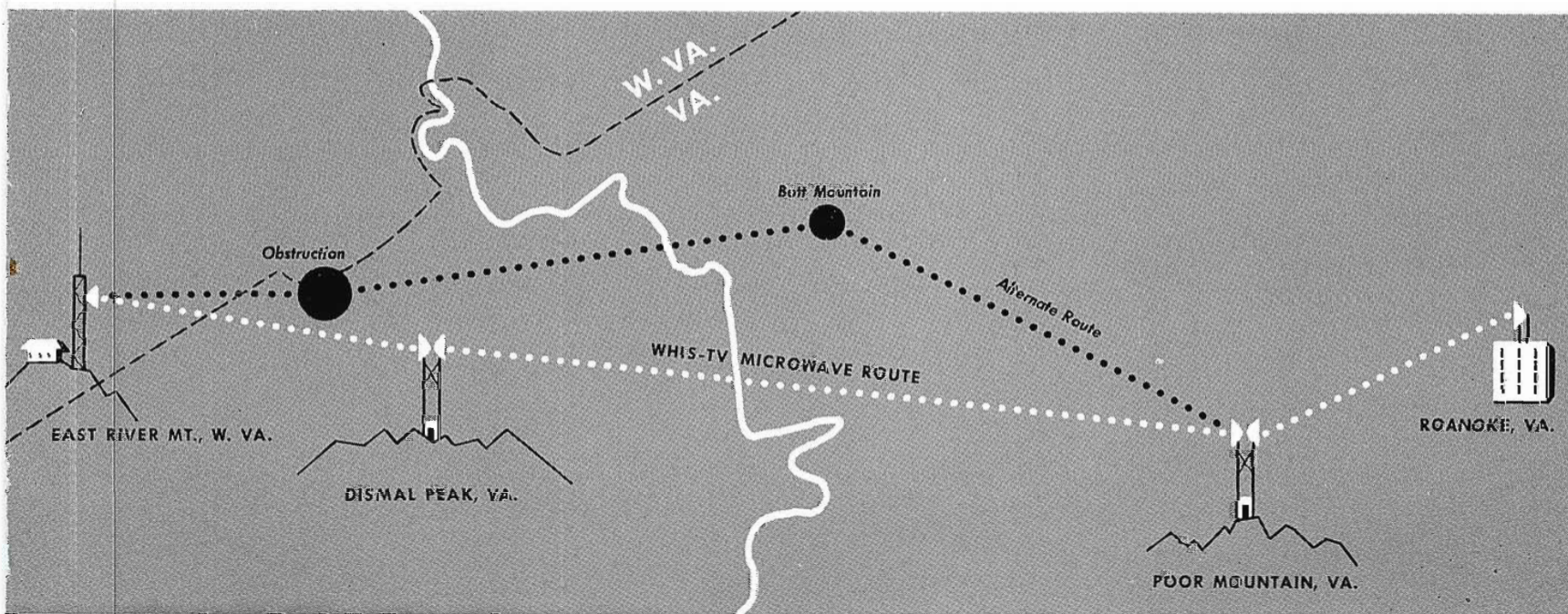

Construction of Relay Stations

It was desired to make the relay towers as simple as possible in order to keep expenses under control and get into operation as rapidly as possible. To achieve these ends an arrangement using telephone poles was designed to support antennas and head-end units but no compromise was made, however, with clearance requirements. Armco sheet steel pre-fab structures measuring 10 by 8 by 8 feet were used for housing radio equipment at the base of the relay stations.

The Cofer Construction Company of Roanoke contracted to do the outdoor erection of buildings and antenna supports. A poured 6-inch thick concrete slab was used for the foundation of the sheet steel building. Pouring required one day and building erection required another day. Two men took one full day to erect the structure.

FIG. 9. Construction of typical microwave relay tower using 4 telephone poles for supporting 6 foot dishes and head end equipments for transmitting and receiving.

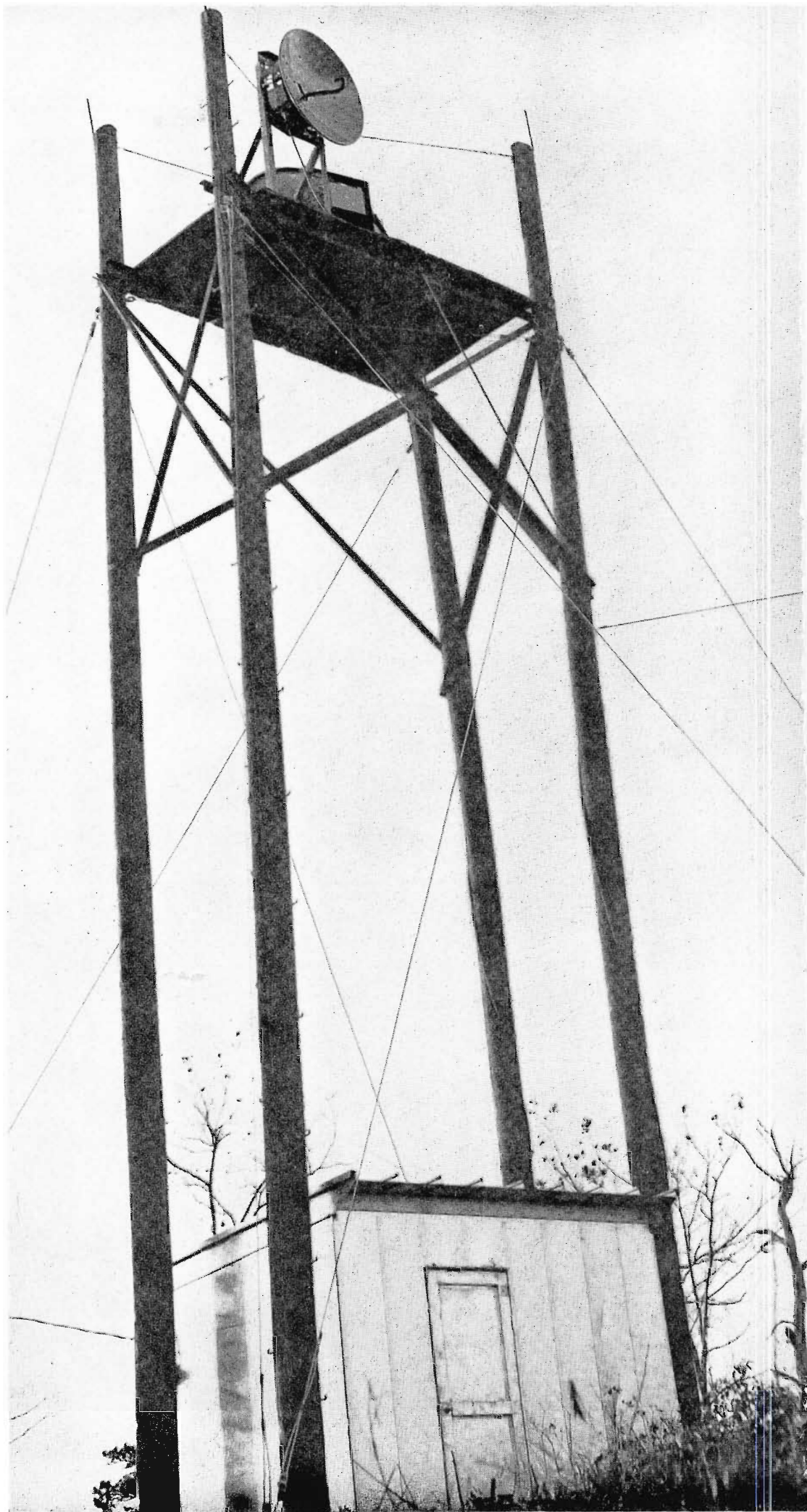

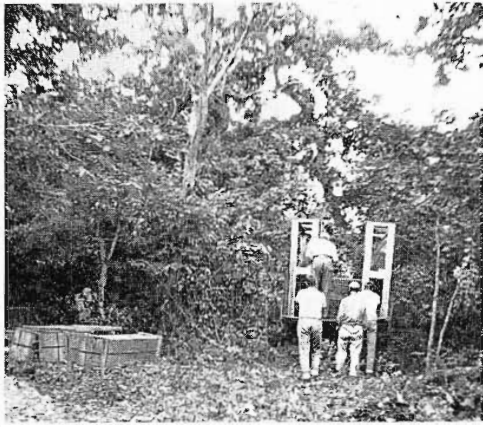

FIG. 10. Unloading material at Dismal Peak relay site.



FIG. 11. Construction of relay station at Dismal Peak, Virginia.

The towers for antennas consisted of four creosoted 50-foot telephone poles, arranged to form a rectangle 6 by 12 feet. The poles were sunk $4\frac{1}{2}$ feet into the ground. A platform arrangement, 5 feet from the top, supported antennas and external equipment. The contractor spent one day digging holes and two days for erecting the structure. Six men were used in this stage of the job.

Angle iron arrangements used for supporting the parabolic antennas and equipment were designed by Flanagan and fabricated in the WHIS-TV Bluefield shop. These were then fastened to the platform, antennas were mounted, and

head-end units installed. The platform is large enough to allow several men to work at one time.

One rack houses all the microwave relay equipment in the pre-fab building at the relay station. The rack contains transmitter control panel, receiver control panel, and power supply (see Fig. 13). Both relay stations operate completely unattended.

The platform at the top of the 4-pole tower makes it convenient for serving the head-end units and the antennas. Eventually it is planned to enclose the platform so that service can be more conveniently carried on in all kinds of weather.

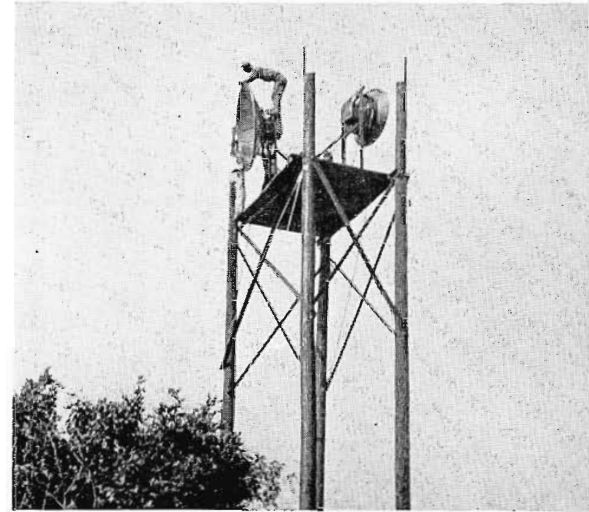

FIG. 12. Orienting parabolic reflector at Poor Mountain to line up with Dismal Peak.

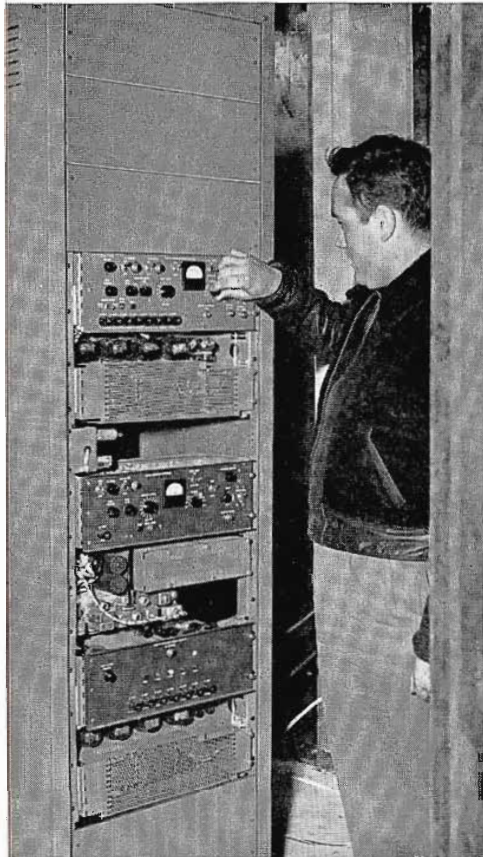

FIG. 13. Engineer Oliver Lienhard adjusting microwave equipment in relay station building at Poor Mountain.



FIG. 14. Pat Flanagan, Administrative Director of Radio and TV, at door of typical Armco sheet steel pre-fab building used at relay sites.

FIG. 15. Rear view of roof top microwave installation at Roanoke.

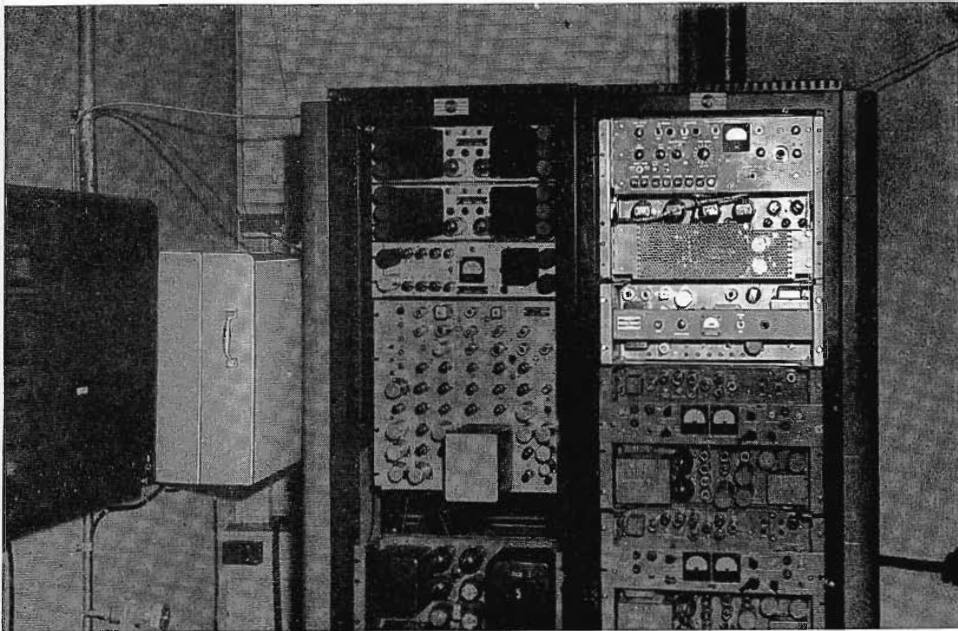
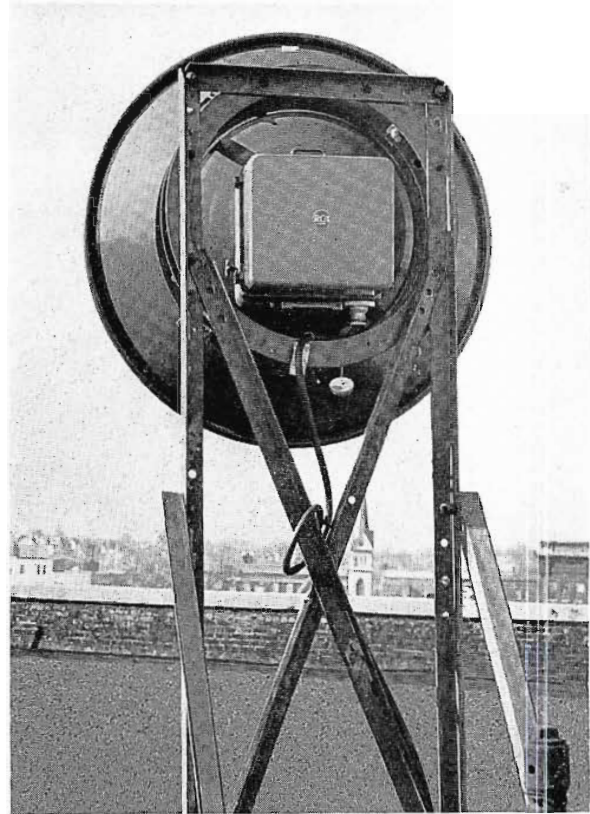

FIG. 16. WHIS-TV microwave equipment in WDBJ studio at Roanoke in upper part of rack at right. Note AT&T terminal box at left.

FIG. 17. Power line 1.25 miles long was built to serve installation on Dismal Peak.



Point of Origin

The WHIS-TV microwave connects into existing AT&T circuits in Roanoke. Arrangements were made with Station WDBJ in Roanoke to lease space for location of microwave equipment. The microwave antenna is located on the roof of the Mountain Trust Building, which houses WDBJ studios. No tower was needed at this point; it was merely necessary to fabricate an angle iron supporting structure to elevate the parabolic antenna eight feet above the roof level (see Fig. 15).

The microwave transmitter control panel and power supplies are mounted in less than half a rack in the WDBJ film room (the rest of the rack contains WDBJ equipment.) Only other piece of equipment used by WHIS-TV in this room is the AT&T terminal box (see Fig. 16).

Problems at Dismal Peak

At this relay site several difficulties took quite a bit of time to iron out. The site itself is located in the Jefferson National Forest. It was the only acceptable point to get a direct and unobstructed path. Although considerable negotiation was required, the station was finally able to lease an area 100 foot square on the mountain from the Forest Service.

Access roads were not of the best but were in and were deemed adequate for all-weather transportation. Power, however, was not available. WHIS-TV made arrangements with the local electric utility to run some $1\frac{1}{4}$ miles of power line. For some unexplained reason, this took so long that the equipment was installed before

power was available. In order not to hold up testing and alignment, a gasoline-driven motor generator set was temporarily used to power the microwave equipment.

Pre-Testing the System

Prior to installation the RCA microwave radio relay equipment was set up in Bluefield, bench tested, and each piece was marked. After that it was transported to relay sites, to Roanoke, and to the transmitter for installation in racks and on towers. Flanagan and his boys did the entire job.

Before transporting the equipment to installation sites, it was also set up as a complete system and tested. The entire three hops were arranged around the studio. It was operated for sufficient time to get all wiring in order and ready for final installation. This studio setup and test took two days.

Installation of Equipment

Final setups at terminals and relay points were made in four days, using two crews of three men each. This final installation was also done by Flanagan and his men. They traveled from one end of the system to the other, installing the equipment and turning on transmitters and receivers as they went. They began at Roanoke, where the common carrier terminates, and ended up in Bluefield at the TV transmitter site. As they traveled, the signal was received at each site before they left. On the fourth day in Bluefield the signal was received at the terminal, coming through fairly satisfactorily and only in need of final alignment and adjustment.

The antennas were originally oriented by Flanagan by means of a hand compass, allowing for angle of declination, and then more accurately adjusted for maximum signal strength after the equipment was operating. Final tune-up and final alignment of the system were performed by an RCA engineer. There resulted considerable improvement in operation when the RCA engineer re-aligned the "dishes" and re-adjusted AFC for proper operation.

Unattended Operation

The RCA Microwave System is designed for automatic operation. There are no per-

sonnel at relay sites. When the transmitter at the AT&T feed point in Roanoke is turned on, the transmitter at the first relay point begins transmitting, and so on in turn down the line.

No emergency power supplies are employed at relay stations. Commercial power supply has proved sufficiently reliable to avoid this expense. In event of failure, WHIS-TV has made arrangements with WSJS-TV of Winston-Salem, N. C., to pick its NBC signal off the air for rebroadcast.

Should anything go wrong, such as power loss at a relay station, the system will shut itself down. This is accomplished by means of the carrier-controlled radiation switch. Each transmitter is tied into the preceding receiver by being wired into its AGC so that if carrier is not received, the transmitter is shut down. Upon failure at any point for any reason, this effect is cascaded along the "line" in order to shut down the entire system. When the fault is cleared, the system automatically starts up by means of the Roanoke signal.

Service and Maintenance

A plan has been set up for routine maintenance at terminals and intermediate relay points of this system. A routine schedule calls for two visits per month to each unattended station. To perform these duties one additional man has been hired. The microwave system is his sole responsibility.

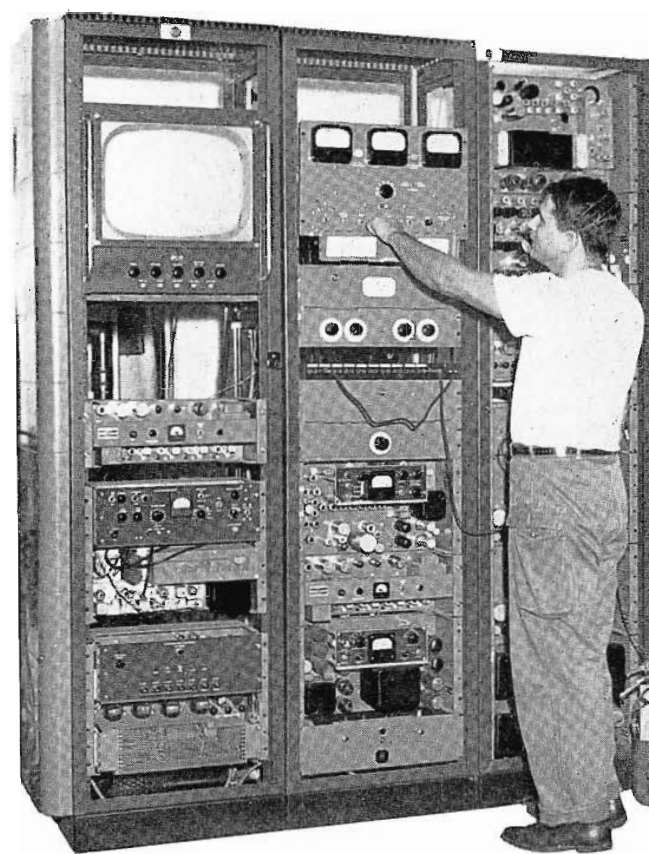

FIG. 18. Microwave equipment in station transmitter room. Left rack: microwave from Roanoke (NBC). Center rack: microwave from Bluefield (STL). Right rack: power supplies.

It is his job to travel up and down the system, making necessary checks and adjustments to keep the equipment in top operating condition.

Results of First Few Months of Operation

"Bugs" were ironed out, the system shaken down, and operation reached a consistently good state during the first month of operation. Interference caused by the signal of another station was eliminated by changing polarization on the antenna that picked up the interfering signal. As operating personnel are becoming more familiar with the new equipment, its tuning and alignment, operation is becoming more and more satisfactory. All in all it appears that performance is now on the same high level as studio and transmitter equipment.

In spite of the newness of the microwave equipment to Pat Flanagan and his crew, they experienced little difficulty in the first month of operation. The system has proved to be dependable and in the instance of a failure was readily returned to service. Both of these qualities of dependability and serviceability are the prime requisites required of equipment that is to operate at remote, unattended locations in a microwave system such as that used by WHIS-TV. Thus, the RCA model TVM-1A microwave relay, which has been designed to provide these features, is now proving itself in the rugged, mountainous country along the Virginia-West Virginia border.

HOW TO MAKE LIVE COMMERCIALS USING RCA 3-V COLOR FILM CHAIN

By S. L. BENDELL, H. N. KOZANOWSKI and T. J. SHIPFERLING

Broadcast Studio Engineering

By employing a relatively simple extension lens system the RCA TK-26A 3-V Color Film Camera can be used to produce color opaques and live color commercials of actual products. The lens arrangement used is shown in Fig. 1. A small rotatable mirror permits this lens system to pick up either 7½ by 10 inch color opaques or products located on a display table. Products can be moved, liquids poured and products demonstrated—all in a normally lighted room.

The system requires no physical or circuit modifications in the TK-26A 3-V film equipment as supplied for film and slide reproduction. Operating conditions remain

the same so that no compromise in picture quality is introduced.

This simple straightforward method for reproducing color opaques and live commercials makes it possible to extend the revenue-producing power of the 3-V film equipment.

The attractiveness of live color commercials and opaques can be ascribed to the relative ease of preparing original art work, the ready product availability and the ability to make last minute changes in format. Elimination of the time and expense involved in preparing 2 by 2 inch slides for one-shot displays also represents a distinct advantage. Original art work for opaques

can be previewed immediately and reworked and retouched as required to produce the color rendition demanded by the sponsor.

The optical system devised for live commercials is shown diagrammatically in Fig. 2. It begins with an Ektar 90-mm focal-length lens identical with those used on the RCA monochrome and color image-orthicon TV camera turrets to cover the standard 1.6-inch picture diagonal. This lens is focused on the object to be reproduced. A 15-diopter field lens is placed at the back-focus image-plane distance. The 1.6-inch diagonal real image at this plane is thus viewed by the 7½-inch f:2.3 projec-

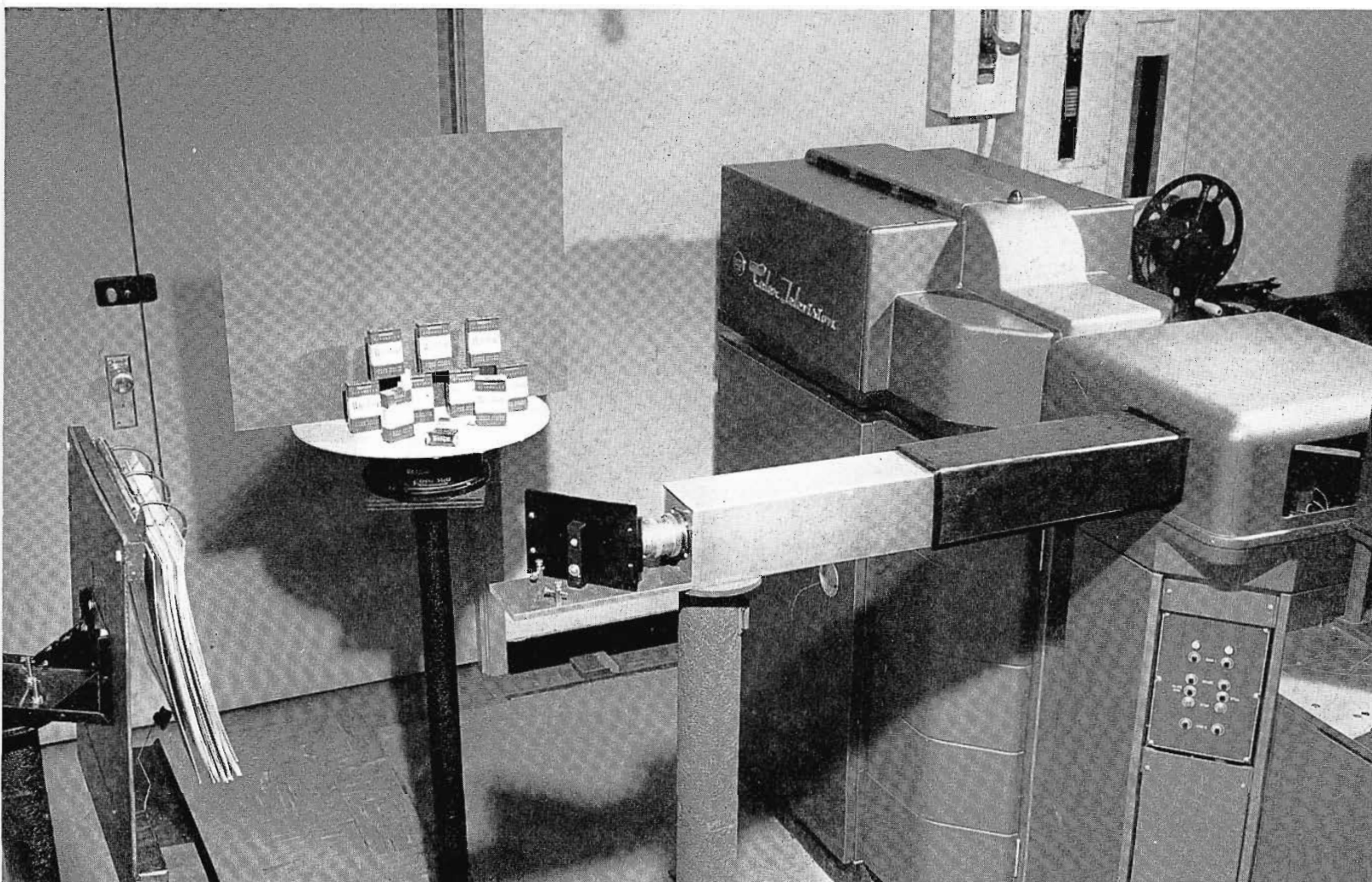

FIG. 1. Lens system added to RCA TK-26A 3-V Color Film Chain for pickup of live color commercials and color opaques.

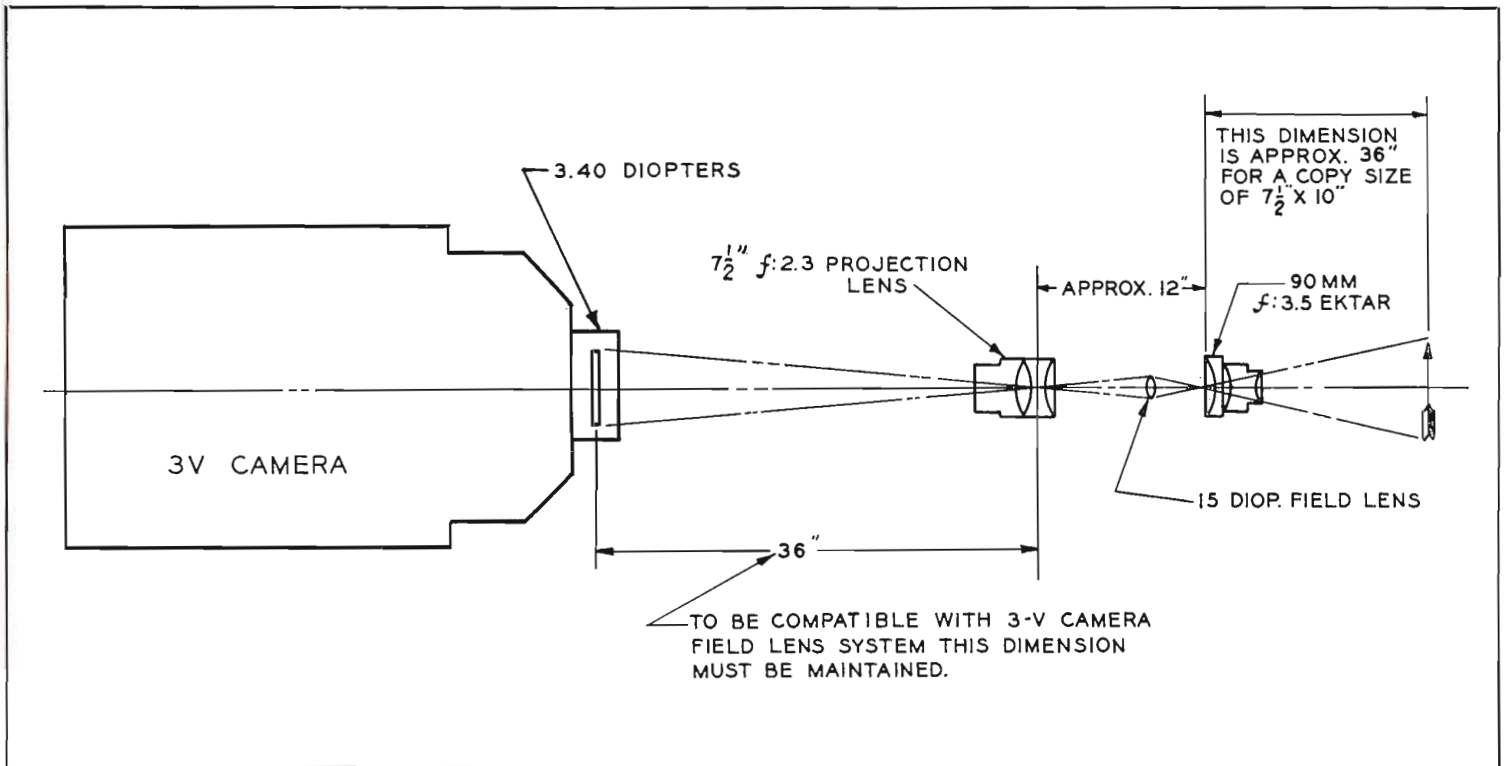

FIG. 2. Optical system showing lens arrangement for live commercial pickup. The Ektar lens is identical with those used on RCA image-orthicon cameras.

tion or relay lens shown in the diagram. This produces a new real image with a 5.58-inch diagonal at the usual picture entry position of the 3-V camera shown at the left.

The lenses used in this optical system were those which happened to be available in the laboratory. However, a commercial study of optimum performance of readily available commercial lenses has just been

completed, and accurate information on recommended lens types and optical spacings will be supplied to broadcasters who now have 3-V film chains.

The purpose of the field lens at the Ektar image position is to redirect rays from the image so that they all enter the relay lens. If the field lens is removed or one of incorrect power is used, the image formed in the 3-V optics will be bright in

the center and dark (or vignetted) at the edge. Proper optics will give uniform illumination in the image.

The situation is identical with that found in the color image-orthicon camera in which each taking lens is associated with its correct power field lens, which is automatically changed with each lens shift in turret rotation. Close-ups or distant pickups can be focused by moving the Ektar

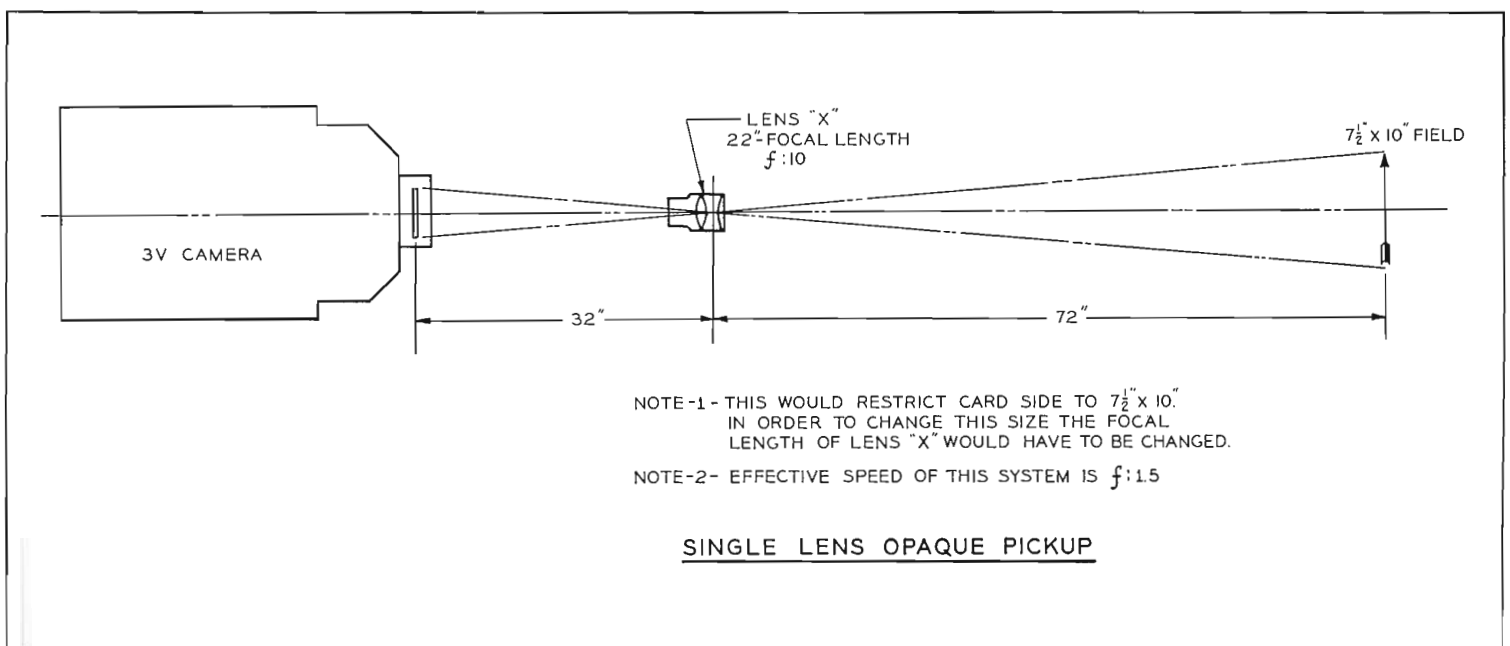

FIG. 3. Brute force optical approach demonstrates design flexibility of first lens arrangement shown in Fig. 2.

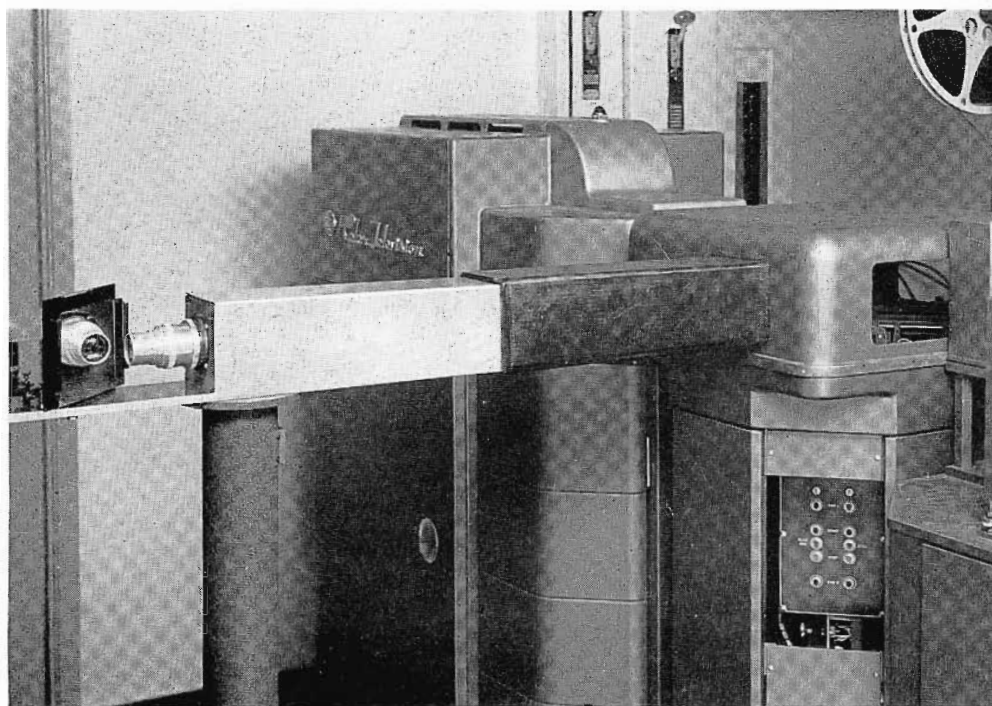

FIG. 4. Standard 3-V Color film chain with optical system for feeding live color commercials. Light shield and dust covers are in position.

in its mount in the usual fashion. This gives the live commercial system the same versatility in accommodating any size of pickup as is available with a standard camera.

Optical Speed

The optical speed of the system is high and can be made $f:1.5$ at the three vidicon cameras using taking lenses no faster than

$f:4$. The diagonals at the Ektar field lens and the vidicon are 1.6 inch and 0.62 inch. The ratio of these diagonals is 2.6 to 1. Since all light is directed through the system with negligible loss, the optical speed is $f:4/2.6$ or $f:1.5$.

The flexibility and elegance of this optical system can be demonstrated by com-

parison with a brute force approach shown in Fig. 3. Here a lens "X" located 32 inches from the 3-V camera picks up a $7\frac{1}{2}$ by 10-inch opaque and images it directly onto the 3-V field lens shown at the left. The 32-inch throw shown is common to all projector sources and fulfills a necessary condition of constant light cone for freedom from vignetting effects. This makes the position of the object 72 inches from the lens, a rather unwieldy distance.

If other opaque sizes are to be handled, the focal length of lens "X" must be changed accordingly. This complication further restricts the utility of the arrangement. However, it is important to point out that the effective optical speed of $f:1.5$ at the 0.625-inch diagonal of the vidicon can be obtained with an aperture of $f:13.5$ at the 22-inch focal length taking lens.

High quality results with any optical system using field-lens techniques can be obtained only by careful alignment and positioning of the optical components involved. This, however, is no more complicated than the well-known procedures followed in the installation of projectors and other devices in 1-V and 3-V camera equipment.

Arrangement of the Equipment

A development model of a live commercial system feeding a standard 3-V color film chain through a TP-15 multiplexer is shown in Fig. 4. The optical relay system is supported on a rigid column in the position normally occupied by a TP-6 or TP-35 film projector. Dust covers and light shield are in position. Note that there is a pivoted front-surface mirror located close to the 90mm Ektar taking lens. It serves to cancel the left-to-right image reversal introduced by the TP-15 multiplexer mirror used in this arrangement. Thus, normal printed copy is correctly reproduced by the system, and since the mirror is pivoted, two or more sources can be used. The basic system shown in Fig. 4 will correctly reproduce opaques.

Any deviations from Fig. 2 and Fig. 4 must contain either no mirrors or an even number of mirrors to avoid backward reproduction of printed and written material. In transparencies this is of no importance, since the orientation of the slide in the projector can always be changed to take care of any horizontal or vertical reversals.

Figure 5 shows a view of the optical system with covers removed. The 90-mm $f:3.5$ Ektar lens, 12-diopter field lens and $7\frac{1}{2}$ -inch $f:2.3$ projection Ektar lens and mounts used in this particular setup are clearly

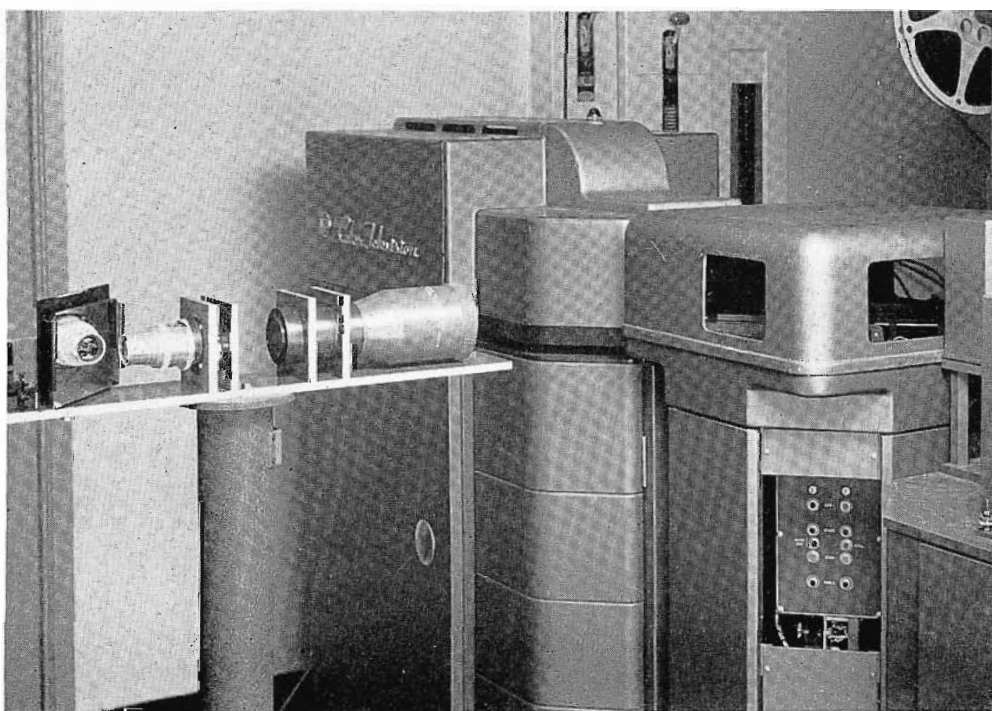

FIG. 5. Lens system—with covers removed—for adding live action color commercials using RCA 3-V film chain.

shown. Figure 6 shows the system setup with 7½ by 10 inch opaques mounted in a drop-card ring binder on a convenient support and with a rotating display table diameter of approximately 16 inches. Rotation of the mirror between two convenient stops allows either source to be selected at will. This lens configuration is typical and probably equally good or perhaps better arrangements will suggest themselves to the television broadcaster.

Lighting Required

In order to have instant changeover from slides or films for "live" commercials the operating conditions must be the same as for film and slide reproduction. This requires incident light of the order of 15,000 to 20,000 foot candles. While this may at first sight appear high, it is of the same order as is used for monochrome reproduction by present day iconoscope and vidicon cameras.

Collimated light sources, such as 1-kw slide projectors with f:2.3 lenses illuminating the 7½ by 10 inch opaque area, are very convenient for this purpose. For illumination of the rotating display table, 500-watt photoflood lamps have been used as shown in Fig. 6. There are no particular problems with the effect of heat on displays.

Both the projector illuminators and the photoflood lamps can be operated at reduced standby voltages, then raised to normal voltage ratings for "on-air" time, using resistors, variacs or magnetic amplifiers. Long life and high efficiency from the lamp sources are then assured. Lamp failures in this service are generally caused by initial starting surges which can thus be minimized. The same techniques can also be adapted for accurate, precision control of video levels.

Conclusions

Tests and demonstrations to engineering and production representatives of network and independent television broadcasting stations have generated high enthusiasm for the results achieved and for the potentialities opened up in programming by this approach. Since there has been no sacrifice in optical performance over film reproduction with 3-V, the resolution and signal-to-noise ratio are excellent.

In picking up small objects, the useful working depth of field is approximately 6 inches, allowing the actual product to be displayed directly with no special preparation as shown in Fig. 7. Vidicons are well-behaved even with extreme highlights, and



FIG. 6. Test setup showing arrangement of 500 watt photoflood lamps on display table and 7½ by 10 inch color opaques behind mirror.



FIG. 7. Live color commercial setup showing product display arranged with a minimum of props.

no halos or edge effects occur in the TV picture. The high lighting level intentionally used for this pickup with vidicon cameras reduces the lag with motion to a negligible amount; and skin tones are faithfully reproduced, thus making possible the use of "action" shots.

As demonstrations have continued, it has become increasingly apparent that the ability of the system to handle live com-

mercials has overshadowed the application of opaque reproduction and has opened up a completely new avenue in program construction. The ability to work directly from art work, printed matter or the sponsor's product with no expenditure for color film or slide reproduction and very little expenditure for special color TV equipment provides an inexpensive method for producing color commercials to accompany color programs.

RECORD 4½ MILLION WATTS ERP PRODUCED IN UHF TV EXPERIMENT

Greatest UHF TV Output Ever Achieved Accomplished With Developmental UHF Power Tube and RCA Super-Power Antenna; Results Promise Extended and Improved UHF Television Broadcast Service

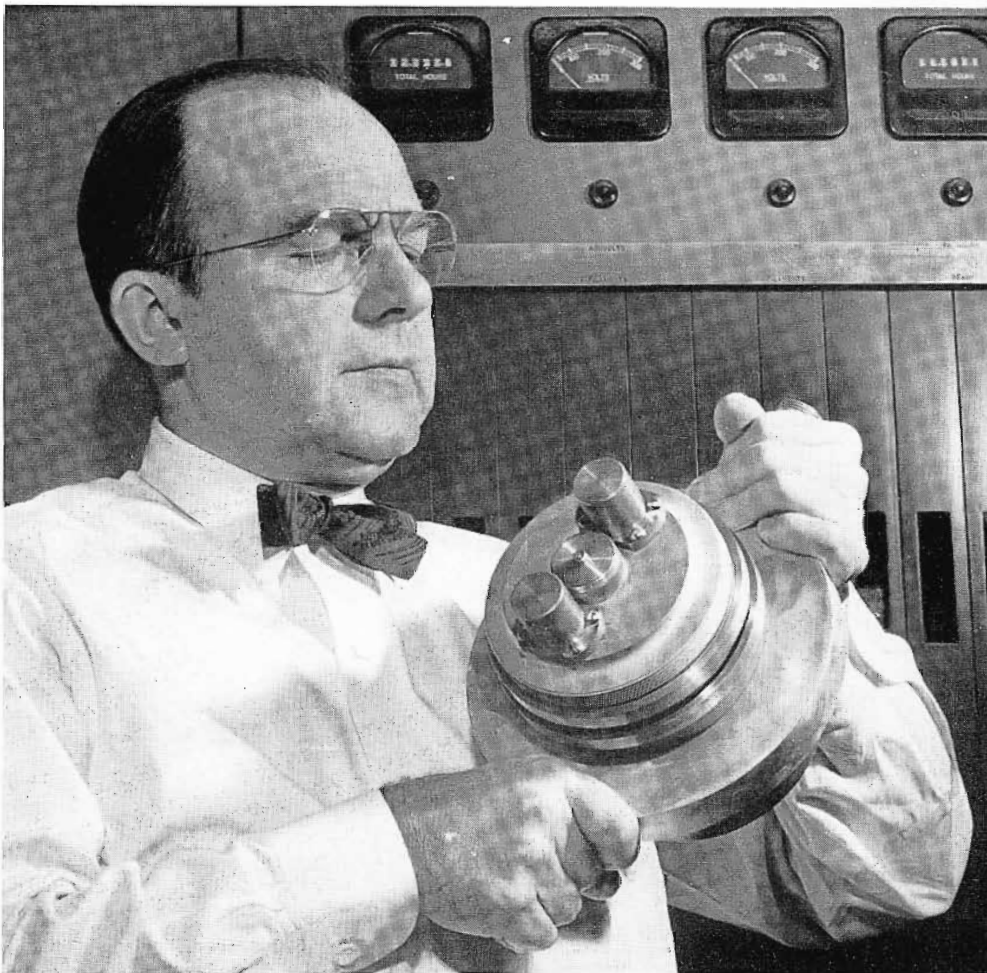

More than four million watts of radiated power at a frequency of 537 megacycles (channel 23) have been produced at Lancaster, Pa. by the Radio Corporation of America. This represents the highest continuous-wave power ever achieved at that frequency, and more than four times the output of the most powerful existing UHF-TV stations. Success of the experiment promises extended and improved UHF broadcast service.

The experiment, latest development in a continuing program to improve UHF-TV broadcast equipment and techniques, coupled an RCA super-power UHF antenna with a super-power, developmental triode electron tube in conjunction with a 12-kw driver to produce the record-high effective radiated power. UHF television stations are permitted a maximum of one million watts of effective radiated power under existing regulations of the Federal Communications Commission. Station WBRE-TV, Wilkes-Barre, Pa., which went on the air a year ago as the nation's first million-watt UHF-TV broadcaster, utilizes an RCA super-power antenna similar to

This is the super-power developmental triode used in the experiment. Operation of the tube is Class B, grounded grid—with a modified TTU-12 UHF transmitter driving the tube. Holding the tube is Dr. L. P. Garner, head of the power-tube group that designed the tube.



Approximately 4½ megawatts are produced by feeding 100 kilowatts into this super-power antenna with a gain of nearly 50.

that employed in the Lancaster experiment. A similar RCA antenna is used by UHF station KPTV, Portland, Oregon.

The 4½ million watts of radiated power were produced by feeding approximately 100 kilowatts into the antenna which has a gain of nearly 50. The tremendous power was generated by a developmental triode electron tube designed by a power-tube group headed by Dr. L. P. Garner.

This successful test establishes the engineering validity of ultra-high-power, ultra-high-frequency broadcasting. Radiated power in the order of four to five million watts would enable UHF-TV stations so equipped to provide saturation broadcast coverage in primary areas and to offer vastly improved television service throughout so-called fringe or weak-signal areas.



Inspecting the final stage is Mr. Irvin Martin, a member of the power-tube group. The input cavity and a portion of the output stage are clearly visible.

NARTB ANNOUNCES 3-DAY ENGINEERING CONFERENCE

Broadcast engineers who bemoaned the shortness of last year's two-day engineering conference will be happy to hear that NARTB has planned three full days of technical papers for this year's meeting.

The 10th annual Broadcast Engineering Conference will be held in Chicago on April 16, 18 and 19 in conjunction with the 34th annual NARTB Convention at the Conrad Hilton Hotel.

Departing from past practice, the Engineering Conference will hold its first session on Monday, April 16. The entire first day will be devoted to developments in the fields of monochrome and color television. In making this announcement, Prose Walker, Manager of NARTB Engineering, pointed out that this would make it possible to schedule more papers than last year without extending the convention.

Engineering will meet in a joint session with Management on Tuesday, the opening day of the Management Conference. Highlights of that morning session will be the NARTB Keynote Address and Award and the luncheon address of the Chairman of the Federal Communications Commission. Included in the afternoon session will be the traditional FCC panel discussion.

On Wednesday and Thursday the Engineering Conference will reconvene. Wednesday will be Radio Day and will highlight discussions of remote control, automatic operation, and other important radio topics. Thursday, Television Day, will be devoted to further new developments and operating techniques in that field. The Engineering Committee of NARTB, which is working

with Mr. Walker in making up the list of papers for the conference consists of:

W. J. Purcell, Chairman, Chief Engineer, WGY, Schenectady, N. Y.

E. K. Jett, Vice President, WMAR-TV, Baltimore, Md.

Raymond F. Guy, Director, Radio Frequency Engineering, NBC, New York City.

Philip Hedrick, Operations Manager, WSJS, Winston-Salem, N. C.

T. C. Kenney, Chief Engineer, KDKA, Pittsburgh, Pa.

W. B. Lodge, Vice President in Charge of Engineering, CBS, New York City.

Frank Marx, Vice President in Charge of Engineering, ABC, New York City.

A. D. Smith, Jr., Director of Engineering, Dumont Broadcasting Corporation, New York City.

C. G. Nopper, Chief Engineer, WMAR-TV, Baltimore, Md.

Orrin W. Towner, Chief Engineer, WHAS, Louisville, Ky.

The goal of Mr. Walker and his committee is to present as many papers as possible on those matters which are of most immediate interest to broadcast station engineers. To do this and at the same time maintain balance and objectivity is not easy. However, the record of past meetings proves that the NARTB Engineering Conference can be counted on to provide more practical help for broadcast engineers than any other engineering meeting.

The broadcast engineer who attends this conference will benefit in other ways. For one thing he will have a chance to inspect and study at leisure, all the latest types of

equipment—much of it in actual operation. (The NARTB Exhibit is the only large-size display of broadcast equipment held during the year.) He will also benefit by meeting other station engineers, and swapping experiences with them.

We believe that every station engineer should make an all-out effort to attend this year's conference. And we believe station managers should urge their engineers to attend. It's just good business! A well-informed station engineer can save his station thousands of dollars, not only in installing equipment but in maintaining and modernizing it.

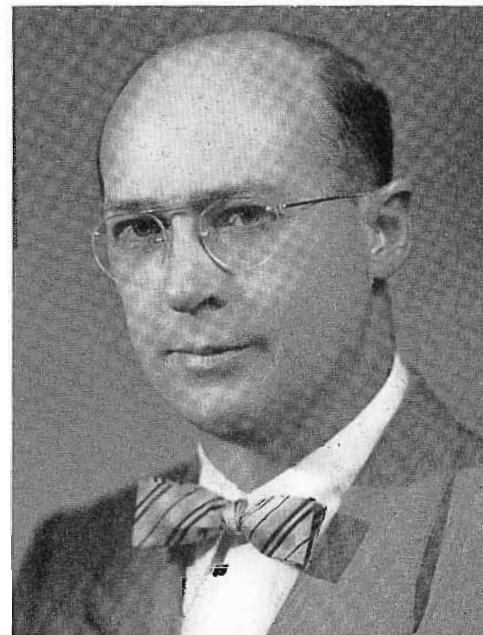

A. Prose Walker, Manager of Engineering for the National Association of Radio and Television Broadcasters.



FIG. 1. The BC-5A Audio Console. Modular construction, nine inputs, three preamps. Has talk-back and program cue to remotes, program and audition facilities. Uses etched-wiring amplifiers.

A NEW, EXPANDABLE AUDIO CONSOLE

Block Building Audio Control Permits Custom Type Installations at Standard Type Prices

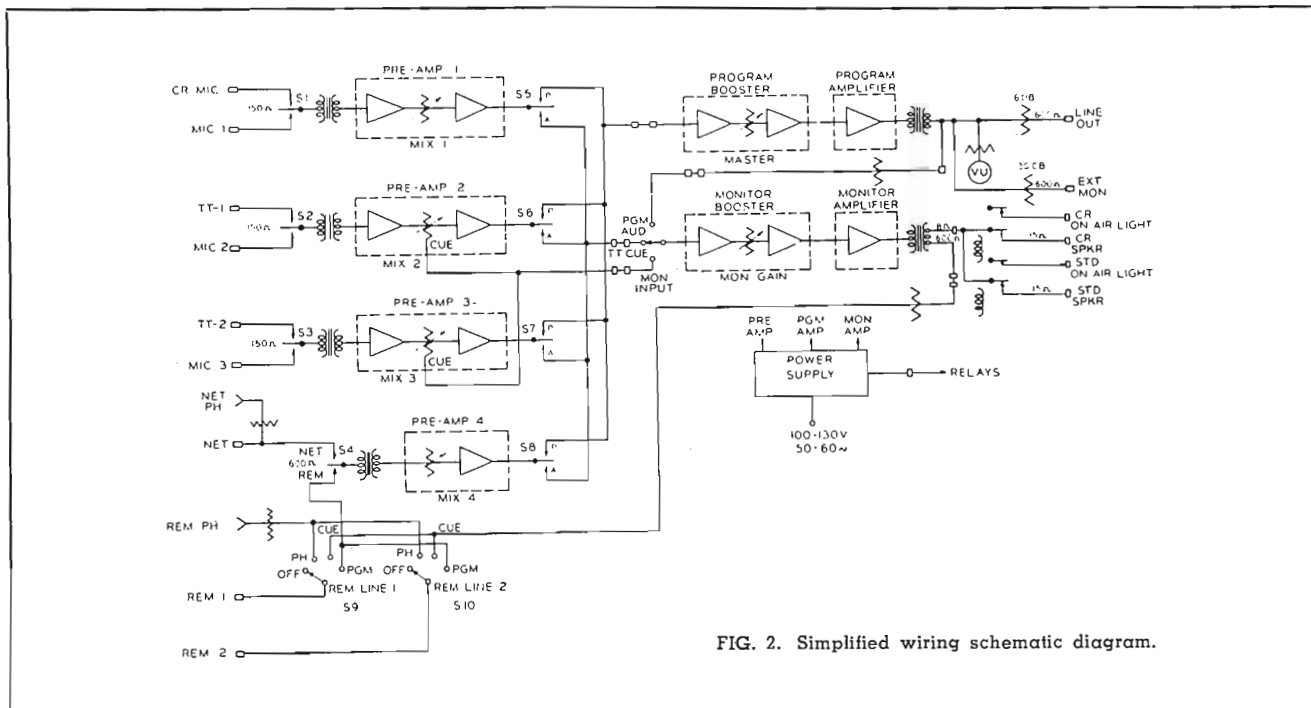

FIG. 2. Simplified wiring schematic diagram.

By E. J. MEEHAN

Sales Administrator

Broadcast and Television Equipment Dept.

A significant development to match the increasing variety of requirements and applications for audio control equipment is offered in the new RCA Type BC-5A console. The BC-5A is rack sized in width, measuring in overall dimension $19\frac{1}{2}$ inches wide, $11\frac{1}{2}$ inches high and $21\frac{1}{2}$ inches deep. It has been designed to handle four microphone inputs, two turntables, two remote lines and network or auxiliary input. The expansion feature permits block building as desired, without obsolescence to the existing control equipment.

The nine inputs available in the BC-5A console provide adequate control and switching facilities for accommodating one complete studio, one announce booth, plus necessary auxiliary inputs such as tape and remotes. The unit is also suitable for "off-peak" operation at a separate transmitter location. Addition of a second BC-5A doubles the available facilities and permits complete dual channel operation. The BC-5A is ideally suited for twin operation as its overall length under such circumstances is about the same as existing console equipment now in use.

With the demand increasing for types of operation requiring more than one program to be controlled simultaneously, the BC-5A fills a function which previously required custom-built audio equipment, namely, to provide adequate control for several output channels at one central location. For example, AM/FM operation where separate programs are utilized on each transmitter, may be fed from a common position using two BC-5A consoles. In FM-only operation where the multiplex type program is operated simultaneously with the basic broadcast program, the BC-5A in the "paired" condition will accommodate two program outputs with adequate control for each channel.

Due to its convenient size, the BC-5A is well-suited for use in television stations as audio sub-control equipment. It also can be used with existing console equipment such as the BC-2B or the new BC-3B (a self-contained unit similar to BC-2B) to provide dual channel operation with more than 20 overall inputs. Use of the BC-5A with the conventional type BCM-1A auxiliary mixer console will provide additional facilities for twelve microphone inputs, any four of which may be used simultaneously. It is interesting to note that the BCM-1A auxiliary mixer is housed in a cabinet identical to the BC-5A. This

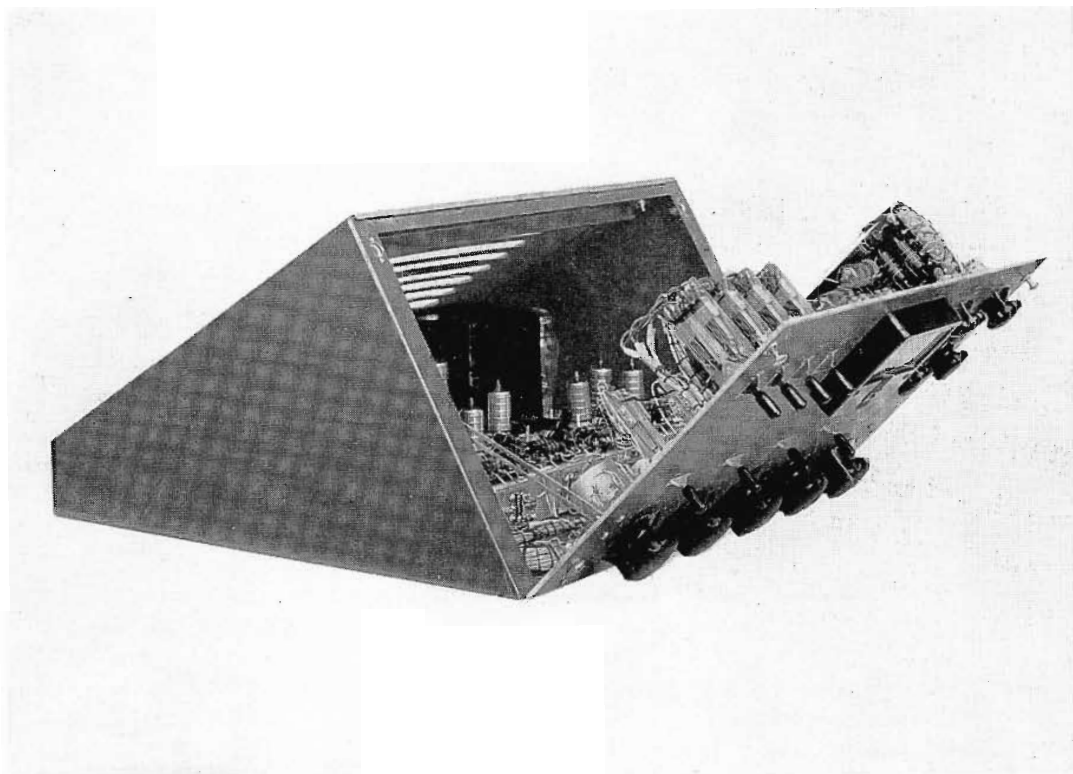

FIG. 3. View showing BC-5A interior by opening front panel. Printed wiring boards are mounted on horizontal chassis. Another is visible at upper right corner inside front panel.

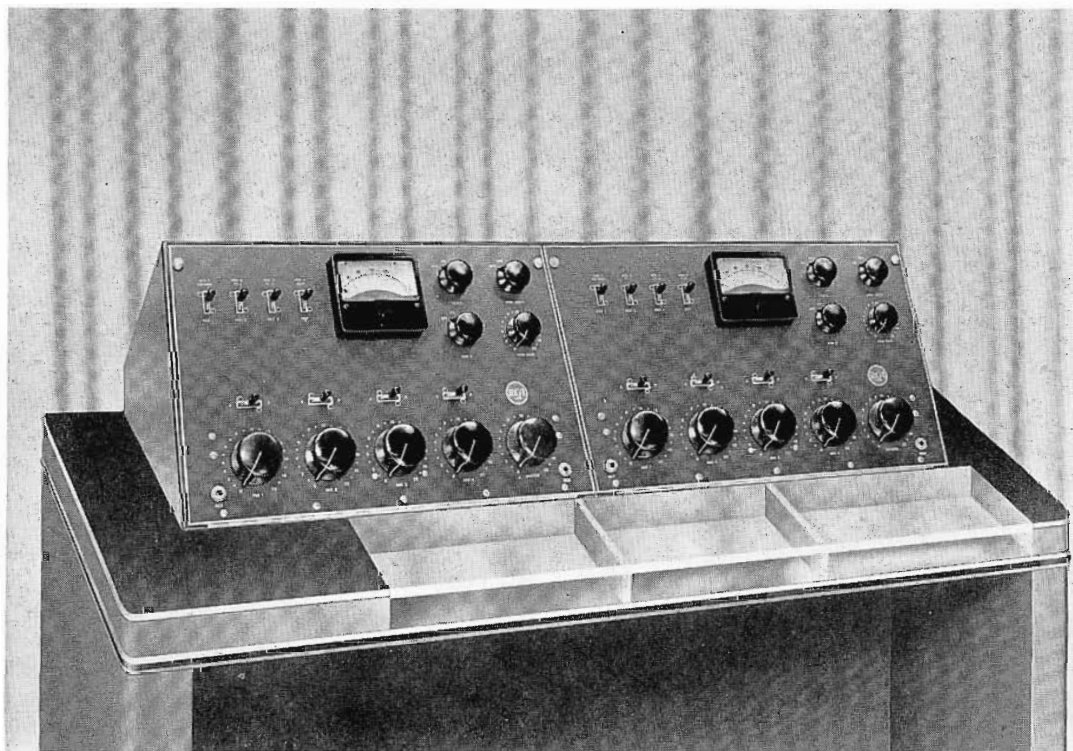

FIG. 4. Expandability of BC-5A facilities is simple and effective by pairing . . . provides dual channel operation.

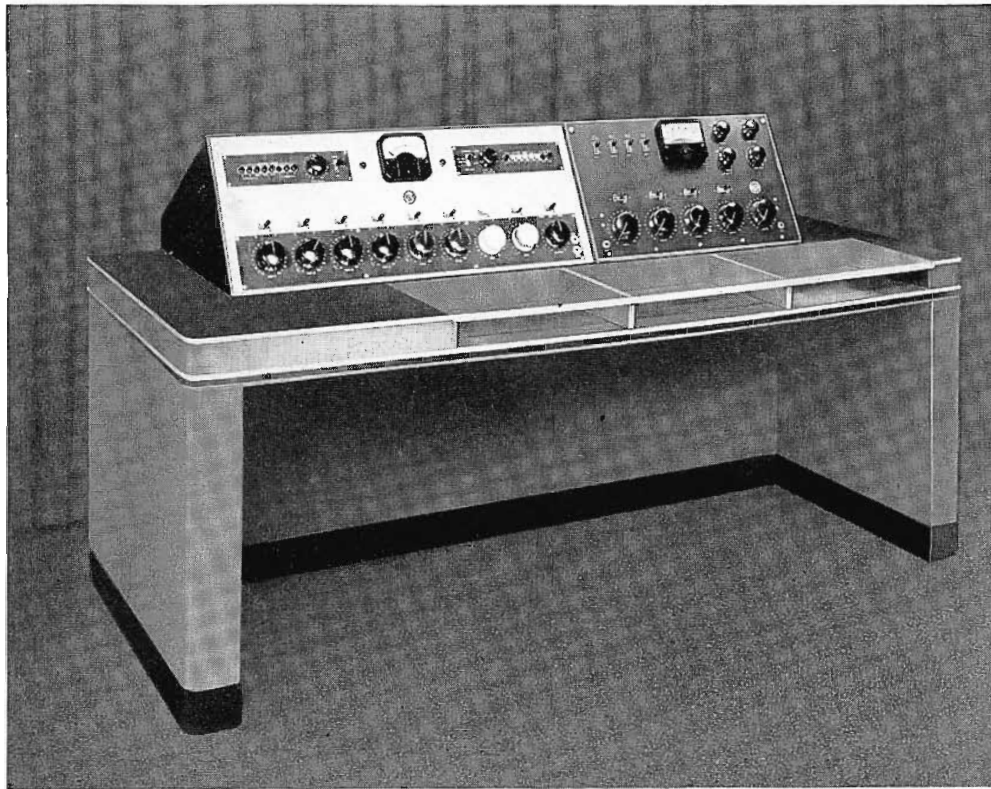

FIG. 5. The new BC-5A can be paired with existing BC-2B's by coupling the output of the BC-5A to a BC-2B microphone input position. The mixer associated with the BC-2B mike position becomes master control over the BC-5A.

permits functional side-by-side operation again from one common control point.

In the tradition of modern console design, complete access has been provided to all components in the BC-5A by utilization of the hinged front panel and removable cover used in all RCA console equipment. Access to such components as key selector switches, pots, mixers, terminal blocks and wiring has been made completely available.

The BC-5A is an entirely self-contained unit. No external power supplies or auxiliary equipment are required for its operation.

Provision has been made in this equipment for feeding program cue or talkback to the remote lines. Headphone jacks have been provided for monitoring of network and remote lines. The VU meter is illuminated to facilitate readings. Cue positions are incorporated on both turntable mixers,

and terminals have been provided for connection in the system of a separate cueing amplifier. In normal operation, however, the monitoring amplifier may be switched between turntable cue position, program line and audition bus. Separate audition and program channels are provided for purposes of flexibility. When switches are in the "off" position, all inputs are terminated.

Modular type construction utilizing RCA's new printed wiring amplifiers is a feature of the design. A total of four preamplifiers are used and provision is made for the addition of external line equalizers. One of the four preamplifiers as supplied is wired for low gain to permit its use with a remote line input. By removal of two jumper wires, however, it can easily be modified to provide normal high gain for microphone or equivalent input.

The outputs of the BC-5A provide one program line, two monitor speakers as well as additional feed for house-monitoring, two remote line cue outputs and one turntable cue output. Overall gain of the system to program line is 108 db while overall gain into the monitoring speaker is 125 db. An overall frequency response of 1.5 db from 30 to 15,000 cycles per second is provided in the program line while the monitor system is flat within 2 db for the same frequency range. Harmonic distortion measured in the program line is 1 per cent at 30 cycles, 0.75 per cent at 50 cycles and 0.5 per cent from 100 to 15,000 cycles. Signal to noise ratio in the BC-5A, measured with mixer and master gain controls set for 68 db gain, is 68 db below 18 dbm output.

Electrical pairing of the BC-5A consoles is accomplished by the simple device of paralleling busses between the equipments.

It is felt that in the BC-5A console, the broadcaster has been provided a new and extremely flexible tool for combining at one control position facilities which previously required high cost "custom" audio equipment. The basic building block pattern into which the BC-5A design has been fitted permits an almost unlimited number of applications for a wide variety of broadcast operations.

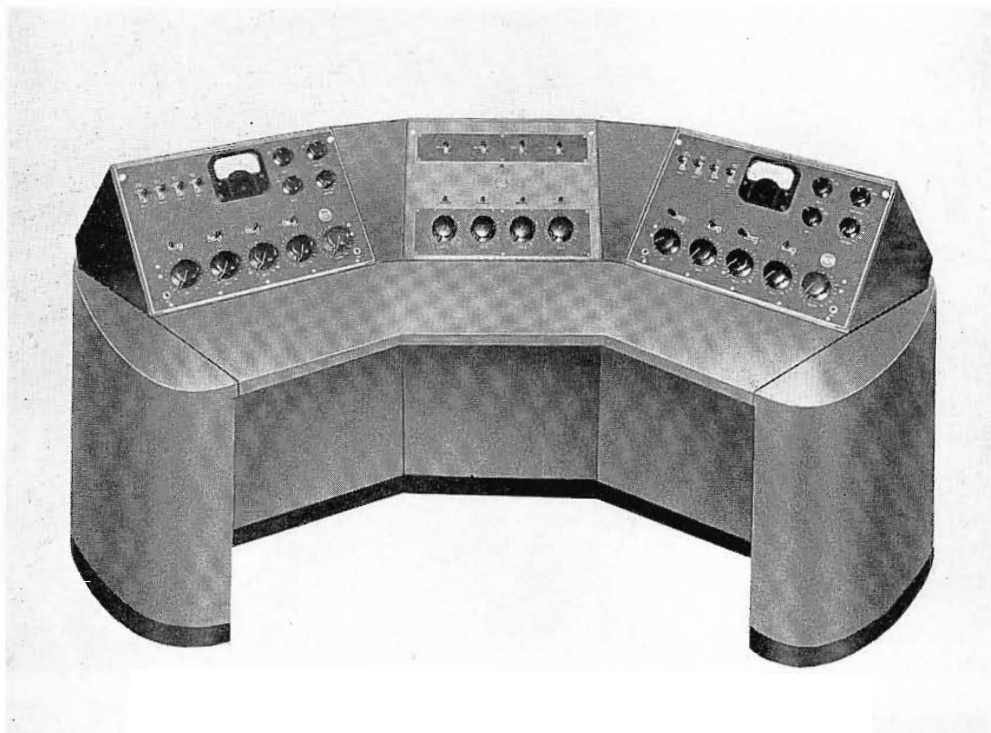
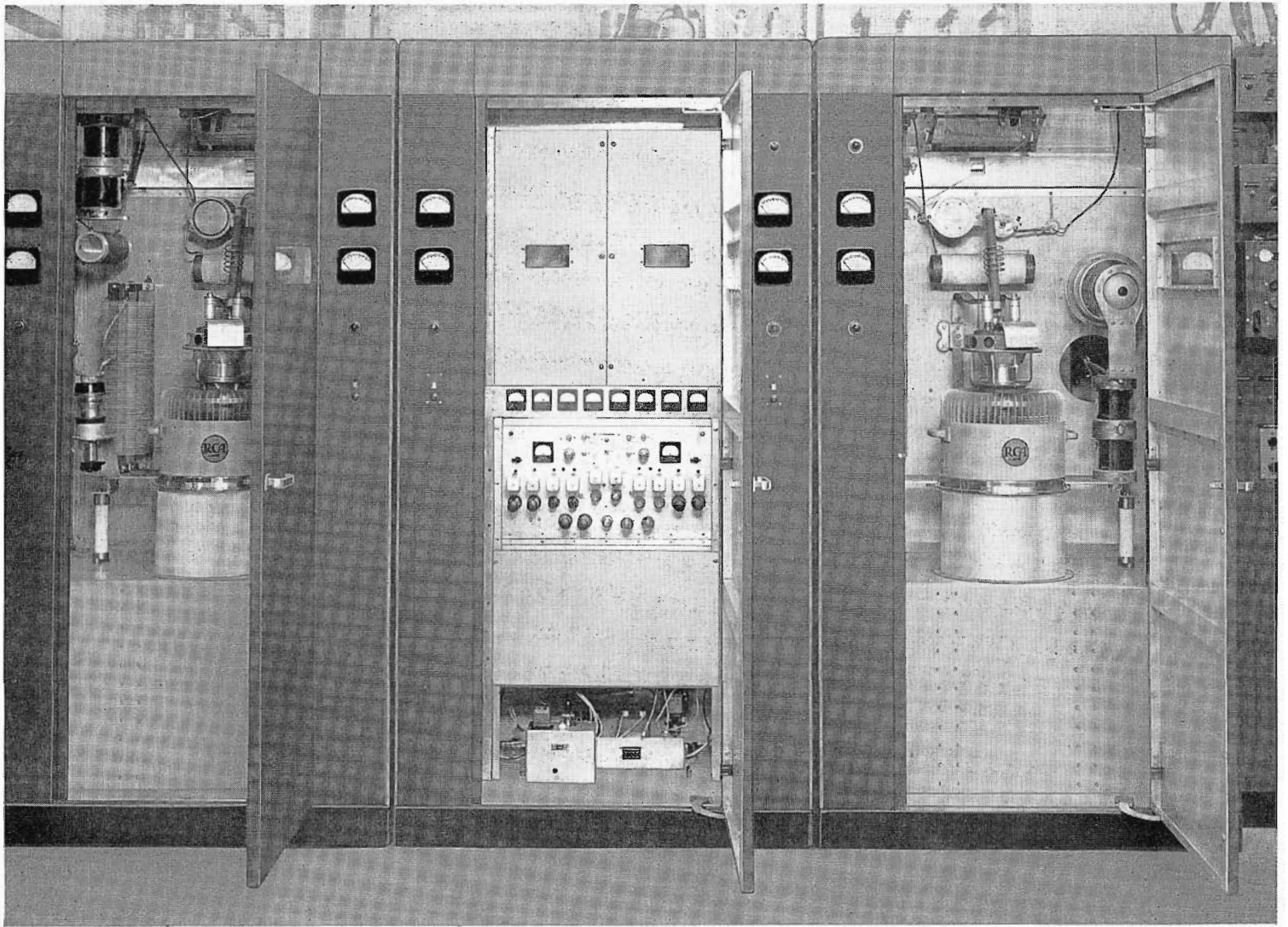

FIG. 6. A deluxe "U" arrangement of two BC-5A's flanking a BCM-1A Auxiliary mixer lends a "custom touch" with considerable versatility. Connections for this arrangement are handled in a similar manner to that described for BC-2B (Fig. 5).



Part of new RCA type BTA-50G AM transmitter just prior to shipment to station WINS. Three of the four cubicles are shown—the two final power amplifier cubicles on either side of the exciter unit.

RCA "AMPLIPHASE" FIFTY FOR WINS

On December 28, 1955, Radio Station WINS of New York City took delivery of the first production model of RCA's new Ampliphase 50-KW AM transmitter. The shipment of this transmitter, embodying the new concept of high efficiency Ampliphase modulation, represents the most significant advance in AM broadcast equipment design in nearly two decades.

WINS expects to reduce broadcast operating costs with the new transmitter in excess of 50 per cent. The saving is provided by lower power consumption, lower tube costs, minimum space requirement and elimination of what has previously been considered required accessory equipment. The transmitter requires only a fraction of the space taken by its predecessor.

Less than 15 feet in length, the BTA-50G requires only half as many expensive power tubes as previous "conventional" designs. Among the many items eliminated in this transmitter are bulky modulation transformers, reactors, water cooling equipment and rotating equipment, which have been used in older model transmitters of this power.

Ampliphase modulation in the BTA-50G utilizes two separated carriers, developed in a common exciter. This carrier is split and fed through two separate amplifier chains, each of which are phase modulated in opposite vectors. At the output of the transmitter the two phases are combined to provide a maximum level 50 KW amplitude modulated signal. Only a few watts

of audio power are required to produce 100 percent modulation, an indication of the transmitter economy and efficiency. Only 100 KW average overall power is consumed under normal modulation conditions. This design combines the efficiency of high-level modulation at r-f with the economy of low-level modulation at audio-frequency.

The BTA-50G is the first transmitter of this power which does not require external cooling equipment. No floor trenches are required since built-in wiring ducts are provided. Thus installation costs at the station are reduced to a very great extent.

WINS broadcasts on 1010 kilocycles with 50,000 watts. The station plans to replace its present transmitter with no loss of air time.

COLORIZING OF WNBQ UNDERWAY

Conversion Of NBC's Chicago Station For "All-Color" Operation Is Progressing According To Schedule

Anyone who had any doubts as to NBC's determination to make WNBQ a completely colorized station should be convinced by the pictures on these pages. Taken the middle of January these photos show the "demolition" of old facilities almost complete, and new construction well underway. As pointed out previously¹ the changeover at WNBQ is being accompanied by an expansion of the space occupied by TV production operations, and a complete refurbishing of WNBQ's studio area.

Plans for the conversion of WNBQ facilities to all-color, and for revamping of the studio area, were drawn by a group of NBC engineers under the direction of Charles Colledge, Director of Engineering and

Technical Operations, O and O Division, working with Howard Lutgens, Manager of Technical Operations for NBC's Central Division. Construction work is being supervised by Ed Nolen of the NBC Video Facilities group.

In order to provide more space for permanent sets (and for large productions involving a number of sets) the old WNBQ TV Control Room (Fig. 1), which formerly occupied a corner of Studio A, is being removed. In addition a large passageway has been opened from Studio A into Studio B. This will enable cameras to be wheeled quickly from one studio to the other—in effect combining the two into one working area.

All WNBQ camera control equipment, and associated equipment, will be installed in a "Video Central" which will be located in the space occupied by the old radio master control (Figs. 3-5). Immediately adjacent to this, in a space which old-timers will remember as the "power and generator" room, will be the TV Studio Control Booth. A large window is being installed so that there will be a good view from this booth into Studio A.

The "Video Central", the TV Studio Control Booth, a Technical Stock Room and a Maintenance Shop will form a single "block" in which all TV operations and maintenance activities will be centralized. This arrangement, which will effect operating economies and make servicing easier and faster is one of the numerous features of the WNBQ color installation which will be described in detail in the next issue of BROADCAST NEWS.

¹"WNBQ to be First All-Color Station." BROADCAST NEWS No. 86, December 1955.

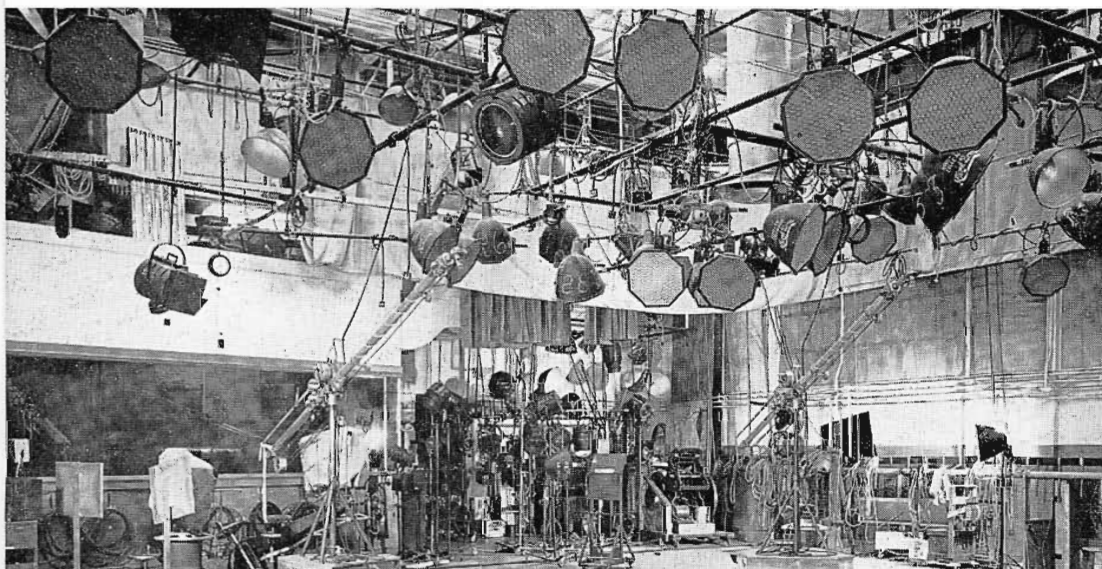
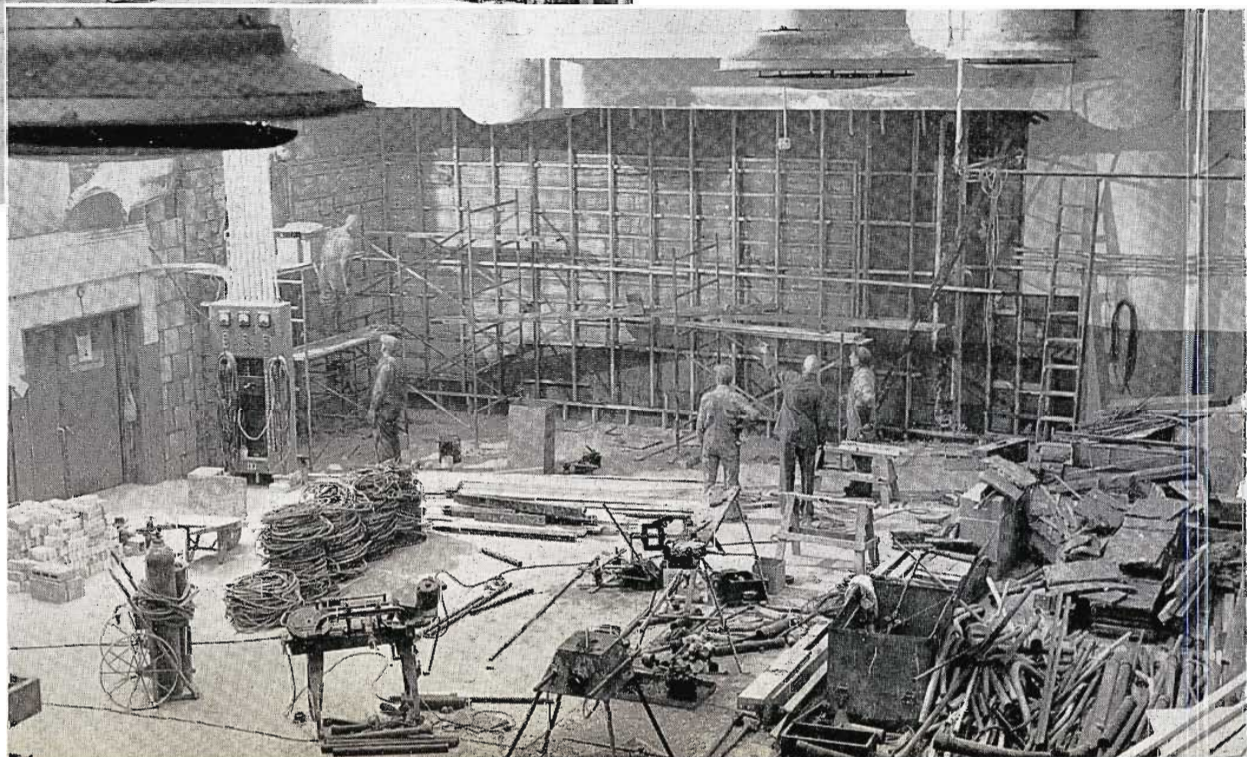

FIG. 1. (left). WNBQ's television Studio A as it looked just a few months ago. At the left rear is the control booth which was used for monochrome operation. To provide more space for color studio operation this booth is being removed. Lighting and air conditioning systems are being modernized and the studio generally refurbished.



FIG. 2 (right). Studio A as it looked in January, with the conversion well underway. Control Booth shown in Fig. 1 has been removed providing greater usable floor space. In addition, a large passageway to old Studio B will make it possible to utilize the space of both studios for large shows.



Evolution of a Landmark

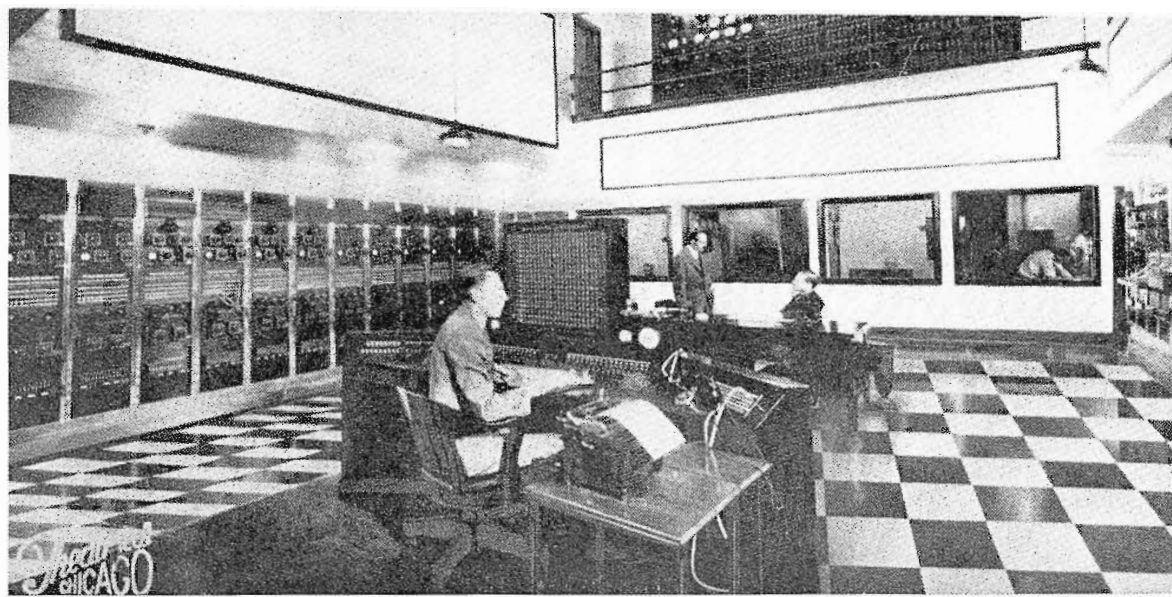

FIG. 3 (top). This picture (reproduced from an illustration in BROADCAST NEWS No. 3, April 1932) shows how the old Radio-Master Control of the Chicago NBC Studios looked in the days when it was the awe-inspiring wonder of the just-dawning electronic age. Nostalgic old-timers will recognize (but not weep for) the rows and rows of battery-operated "speech input" equipment. Battery-charging equipment alone required a control panel (balcony) larger than that of a 50 KW transmitter.



FIG. 4 (center). Radio-Master Control as it looked a few months ago. Over the years the original d-c equipment had been replaced by a-c equipment, and the original small control desk in the center of the room (Fig. 3) by a big board at the end of the room. However, the location, general arrangement, and function of the equipment remained the same as two generations of engineers grew up around it. Probably no control point outside of New York has been so well-known or played such a big part in the development of the industry.

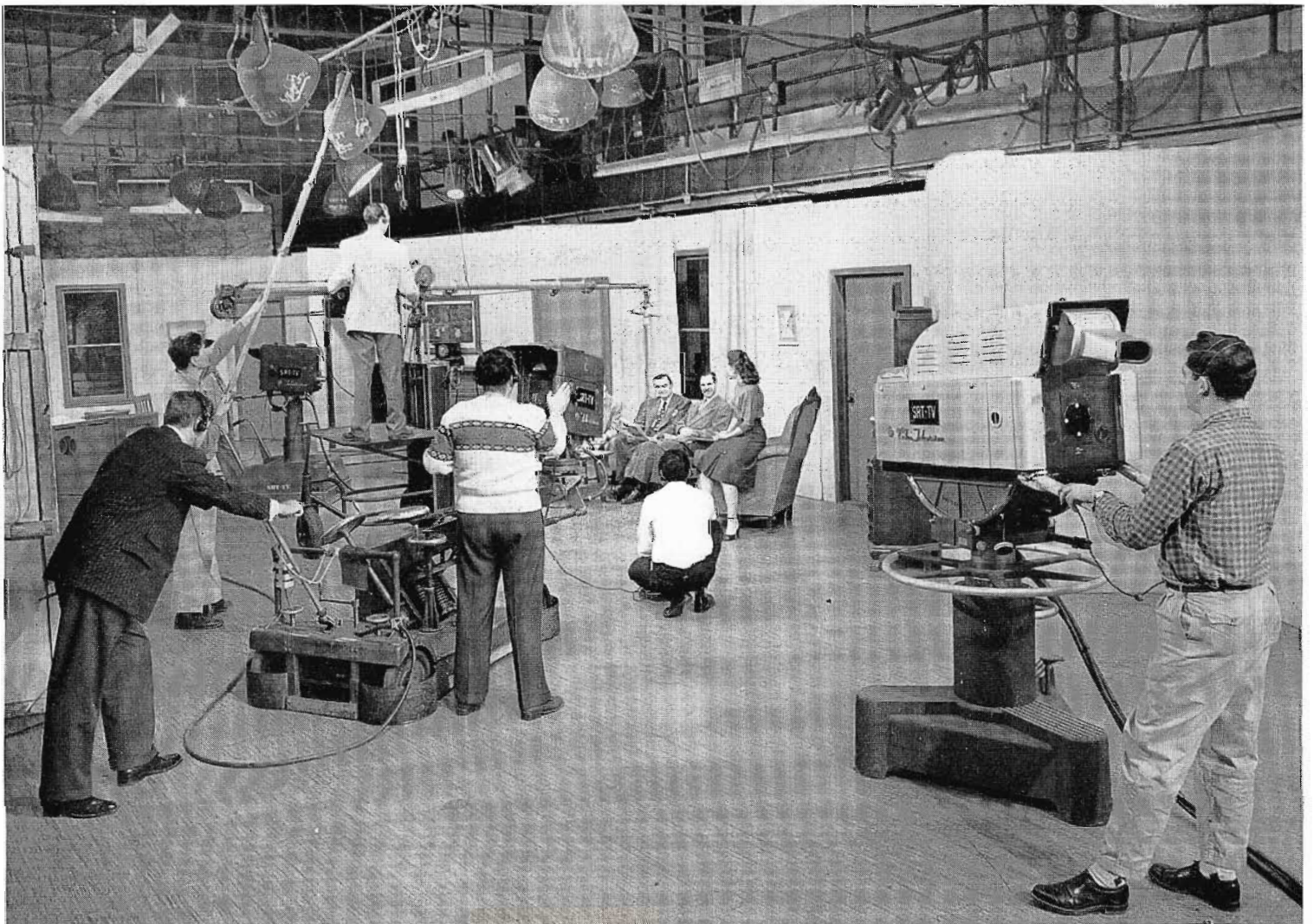

FIG. 5 (bottom). And this is how "old master" looked in January, in the midst of the conversion which will make it the "Video Central" of WNBQ's all-color operation. Radio operations have been transferred to a new radio control room in the front section of the building. All of the audio racks have been pulled out, and the big control board (top right) is on the way to the junk yard. In the new setup all color video control positions and associated equipment for live and film cameras will be located in this room. Video racks will line the room (where audio once stood). Camera control units will form a console in the center. One live color camera chain is already in position (racks at left center, camera control under the plastic covering).



FIG. 1. First use of live color camera by SRT—demonstration of a live color commercial on closed circuit television.

FIG. 2. Overall view of the studio facilities in the large TV studio measuring 50 by 105 feet. Students operate the mike boom, TK-30A monochrome and TK-41A color camera during a rehearsal.



SCHOOL OF RADIO TECHNIQUE ADDS LIVE COLOR CAMERA TO TRAINING FACILITIES

The School of Radio Technique (SRT) offered their first AM broadcasting course back in 1935. Thus, when TV began to expand, it was only natural for SRT to undertake instruction in this medium. Since 1949 the SRT Television Studios have played an important part in the television broadcasting industry, by providing thorough training for a career in this field. With the advent of live color programming, the value of a practical color course was apparent and SRT acquired an RCA TK-41A live color camera chain for instructional purposes.

The rise of TV broadcasting has been spectacular. In the short space of five years this kaleidoscopic industry has grown from infant to giant size. The many special talents that are necessary in a television staff require a curriculum which is both detailed and comprehensive.

Instruction in radio and television at SRT is not limited to lectures, examination of equipment and observation of programs. Teaching methods are based on the philosophy that you learn best by doing—by practicing the skills required. One of the classrooms is a completely equipped TV studio that can and does produce live shows.

Technical Facilities

The large TV studio, measuring 50 by 105 feet, provides more than adequate room for the classes in TV broadcasting. RCA TK-30A image-orthicon cameras make it possible for all students to become thoroughly familiar with monochrome studio operations. The RCA color camera is available not only for instructional use, but for the familiarization of broadcasters in the new color techniques.

Located up above and at one end of the studio is a control room containing two RCA turntables immediately adjacent to an RCA BC-76 consolette. To the left of

the audio operations control are a master monitor and the camera control units for the versatile TK-30A image-orthicon camera chains.

Color Equipment

Control operations for the TK-41A live color camera are centered in a smaller control room at the other end of the studio. It was felt that color and monochrome should be separate for instruction purposes. The camera control unit is mounted in a

control console along with the processing amplifier. The TM-6C master monitor is located immediately to the left of the control console.

The monitor provides for observation of the camera chain's video signals and shows both picture and waveform monitoring of signals at any stage of transmission from the camera to the colorplexer output. A TS-5A video switcher is mounted in the TM-6C master monitor console housing. Two racks containing the colorplexer, color

FIG. 3. Monochrome TV control room has complete facilities for training personnel in all phases of video and audio operations.



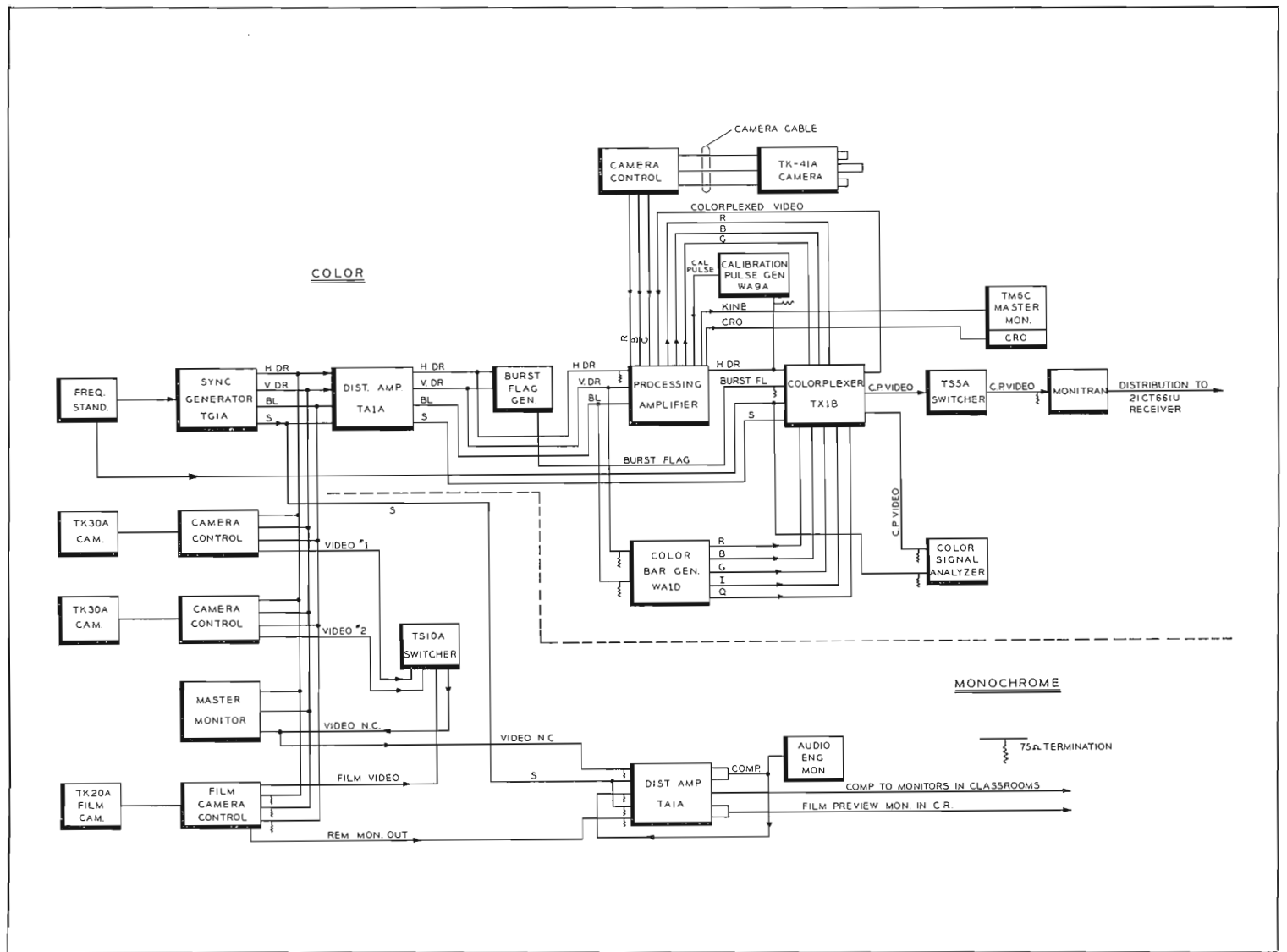

FIG. 4. Complete pulse and video distribution system at the SRT-TV Studios for closed circuit operations.

bar generator, color signal analyzer and regulated power supplies make up the color rack equipment. An oscilloscope and 21-inch RCA color receiver, which functions as a color picture monitor, complete the equipment facilities located in this color control room.

Since film is such an important part of TV programming due emphasis is given to all uses of film for presentation on TV. The film room contains an RCA TK-20A film chain, TP-16 16mm projector and slide projector. Complete equipment is also available for motion picture projection, film cutting and editing.

Type of Student

SRT students come not only from all parts of the U. S., Canada and Latin America, but also from as far away as Thailand, Australia, the Philippines and European countries. The school is justifiably proud of the long list of graduates who

have found useful employment in the radio, television and film industries.

Training facilities at the school are and have been used by several of the major networks to give their supervisory and executive personnel some special courses leading to first-hand indoctrination in the use of TV broadcast equipment.

Top-flight practicing TV professionals make up the veteran faculty that works right along with the students. According to Mr. John F. Gilbert, President of SRT, "A course can never be better than the men and women who teach it."

Courses Offered

Introductory and advanced courses in the following basic TV categories are offered at the school:

- Studio techniques.
- Programming and production.

TV film editing.

Television writing

Design, lighting and special effects.

Motion picture production.

TV management and research.

Assuming that a student has chosen studio programming and production, he gets a course designed to give him a thorough knowledge of the techniques and problems involved. First come fundamentals, an orientation period in which a practical grounding is given in all aspects of TV programming. The student is taught the proper use of cameras and lights, sound, and control boards. He studies the effects of long, medium and close-up shots on the RCA cameras. Cuts, fades, dissolves and other camera transitions are practiced and perfected. Pictorial compositions, control-room terminology, script revision, budgeting time, directing actors, preparing floor

FIG. 5. View of the large TV studio from the color control room located at opposite end of studio from black and white control room. The Color Camera Control Panel is located to the left of Processing Amplifier.

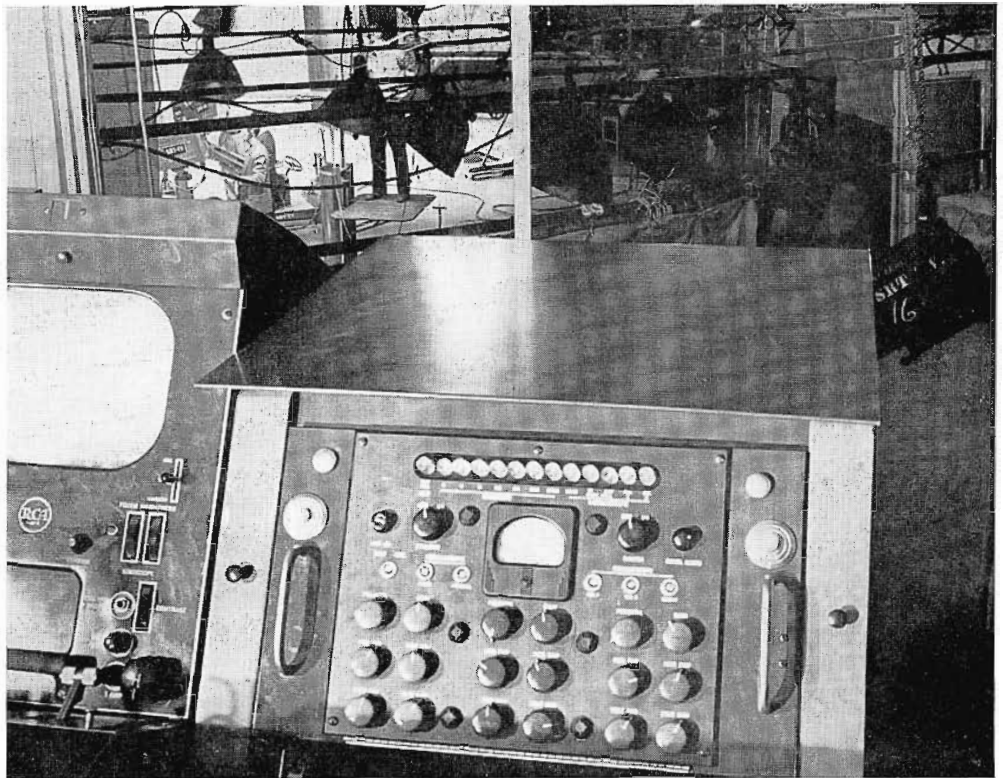
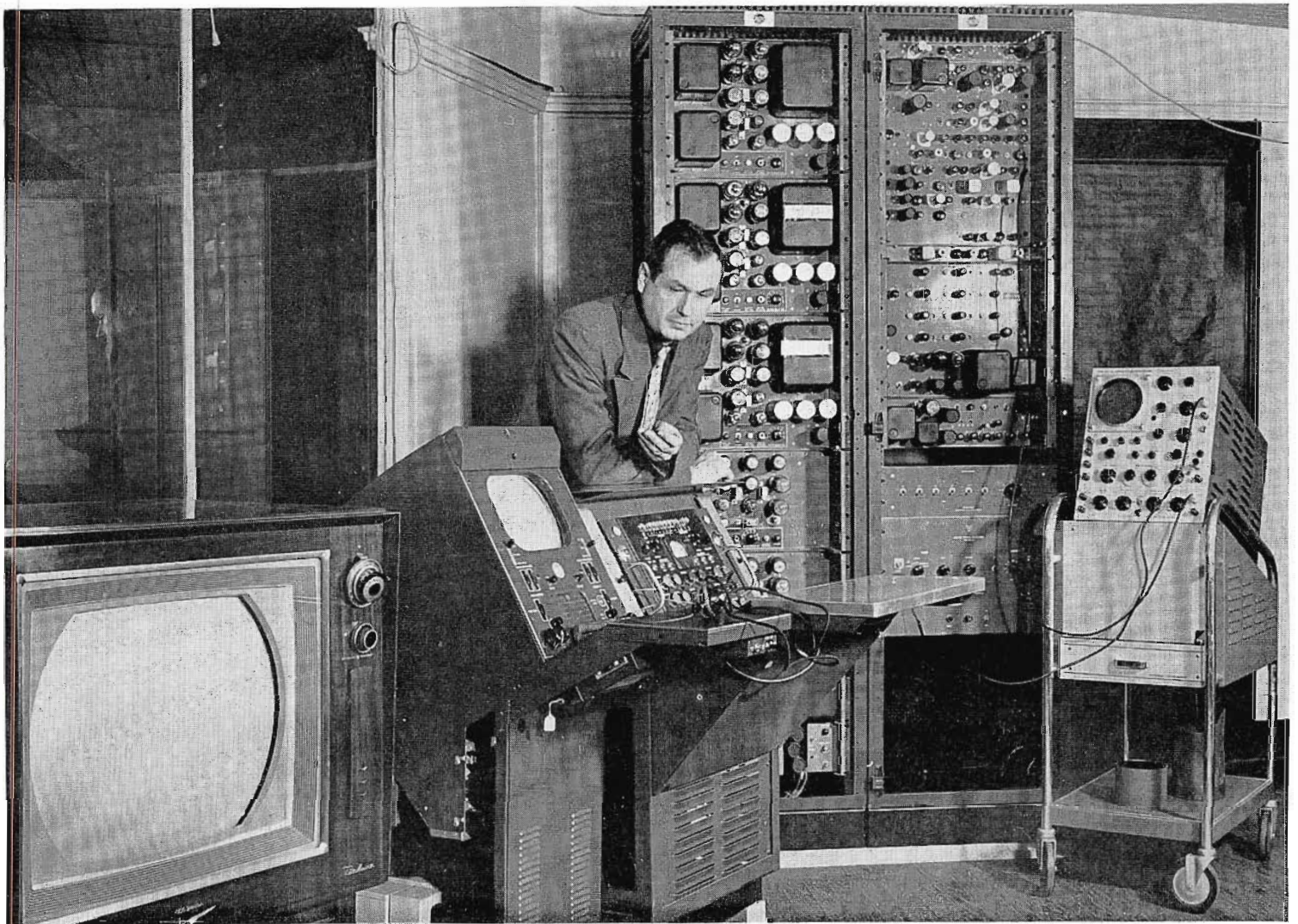

FIG. 6. Color TV control room showing from left to right—the RCA 21-inch color receiver, Camera Control Panel, Processing Amplifier and the associated rack and test equipment.



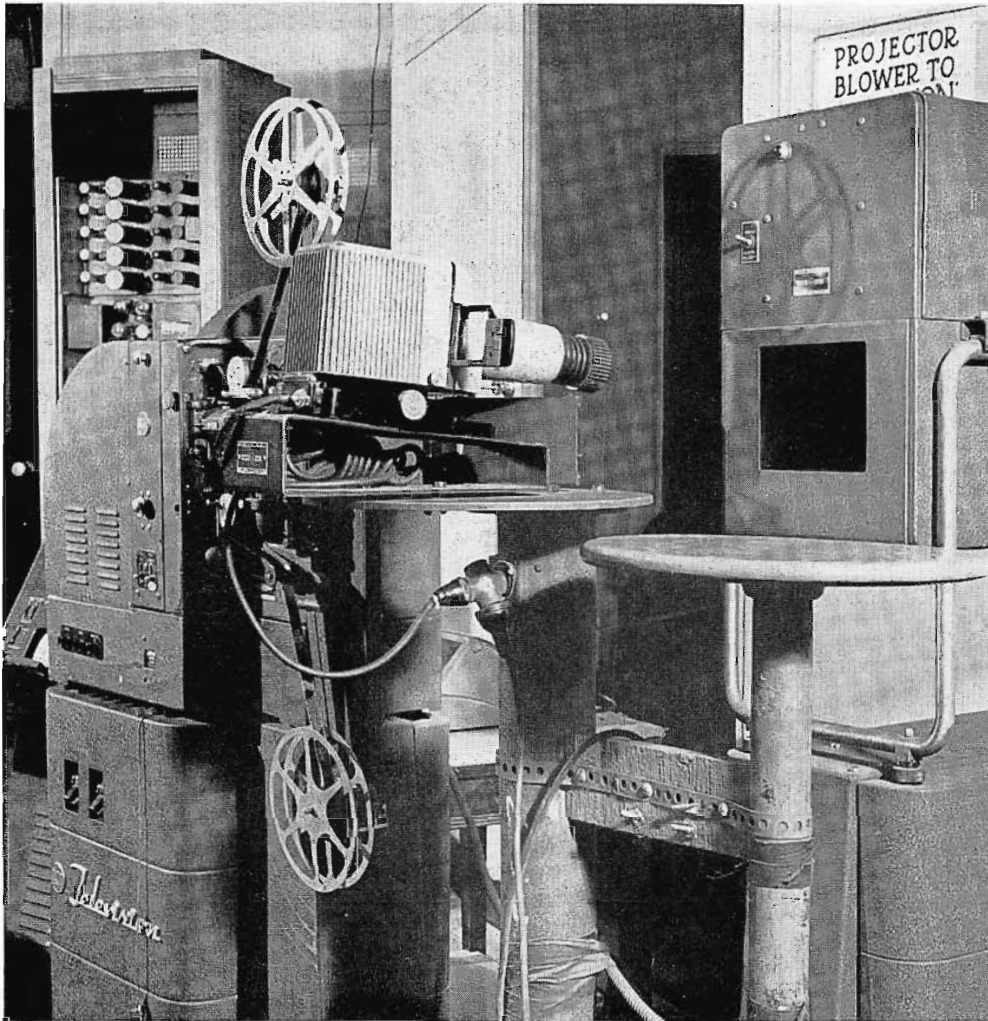

FIG. 7. Film facilities include a TK-20A film camera and film camera control. The projector is an RCA TP-16 16-mm film projector.

plans and planning camera angles and shots prior to rehearsal all form part of the course content.

Guided by professional TV people, the student enters upon the next phase—apprenticeship training. This phase of instruction consists of actual direction of many types of programs such as: interviews, news programs, dramatic shows and quiz programs.

Training results are evaluated during actual programs which the student produces and directs. The accent is on a variety of student program assignments to give as broad a perspective as possible.

Motion Picture Photography for TV

A workshop in the planning and production of 16mm film designed for the TV medium is available. The course emphasizes the actual shooting, editing, splicing, scoring and general handling of TV commer-

cials, newsreels, documentaries and dramatic material. Experience is gained in production shooting both on location and in the studio using black and white as well as color film.

Announcing

The SRT announcing course combines experience not only in radio techniques but television as well. A great deal of work is required on a live mike and before TV cameras. Instruction and full participation are based on network and local station established practice. The course is equivalent to a full year's work in the field according to the school's faculty. The course objective is to have the student ready to assume the full responsibilities of a Radio-TV announcer.

FIG. 8. Rack-mounted TG-1A synchronizing generator, power supplies and distribution amplifier.

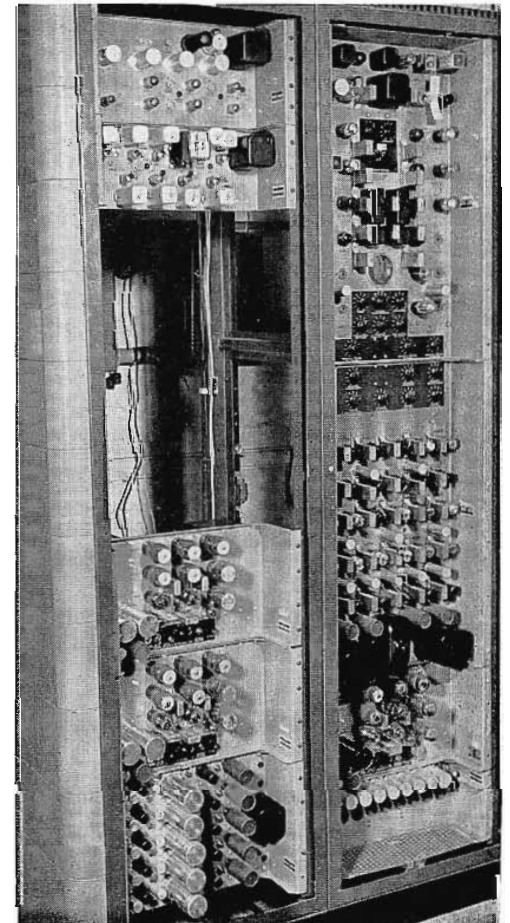



FIG. 9. Students at SRT practicing camera and mike techniques using the RCA TK-41A live color camera chain. All students rotate in the various jobs to get as broad a perspective as possible of studio programming and production.

The students are fortunate in having an instructor as well qualified as Mr. Pat Kelly—formerly Supervisor of Announcers at NBC. Since his retirement from the network he has been Dean of SRT's announcing department.

TV Writing

A practical course in writing for the TV medium is offered. Class sessions in writing techniques of all types of formats are a fundamental part of the course. A minimum of two scripts are required from each student. Actual TV programs are observed and analyzed with the special techniques and technical problems of the TV medium considered in detail.

FCC Operator's License

A course in theoretical electronics, including required mathematics, leads to a First Class FCC Radio-Telephone Operator's License. The course contains no laboratory training and doesn't pretend to equip the student to assume the responsibilities of a broadcast engineer. It is intended to provide the necessary knowledge that will permit the handling of broadcast equipment under the supervision of an experienced engineer.

Another objective of the course is to broaden opportunities for employment for graduates where possession of a First Class FCC ticket will qualify announcers for "combo" jobs on radio stations. Some tele-

vision and radio stations also desire their cameramen to hold FCC First Class tickets.

Instruction at SRT is also available in the principles and practice of time selling, acting and a special course for women in advertising techniques, with particular emphasis on the presentation of television commercials.

As the oldest institution in this country devoted exclusively to the broadcasting arts, SRT can be justifiably proud of past accomplishments. However at SRT they seem to be more temperamentally suited to looking ahead. This they have again demonstrated by being the first educational institution to have complete, live-color studio broadcast equipment.

TWO NEW RCA AM TRANSMITTERS . . . BTA-1MX and BTA-500MX

by E. J. MEEHAN
and
A. W. POWER

RCA Broadcast and TV Equipment Dept.



With the increasing swing of many low and medium powered AM stations to remote-controlled types of transmitter operation, the parameters of AM transmitter design have been shifted to provide a maximum of remote control adaptability with utmost simplicity of installation. This feature has been incorporated into the new RCA Type BTA-1MX, 1000-watt unit and its companion, Type BTA-500MX, 500-watt (expandable) AM transmitter.

Broadcasters, eager to attract new listeners who are indicating high-fidelity interest,

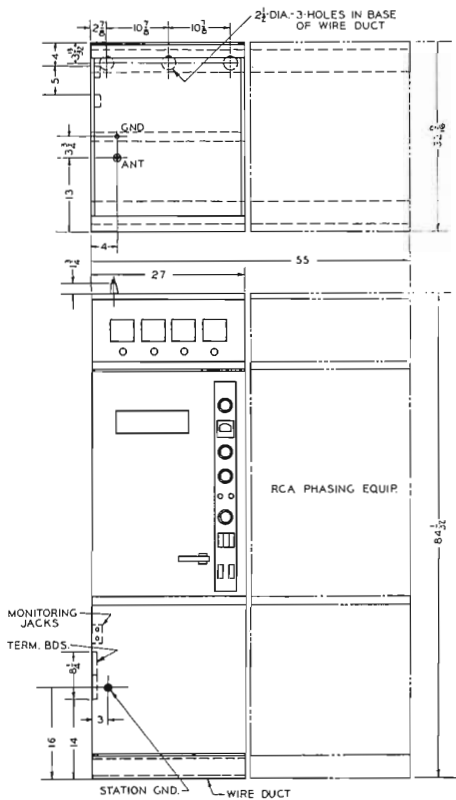
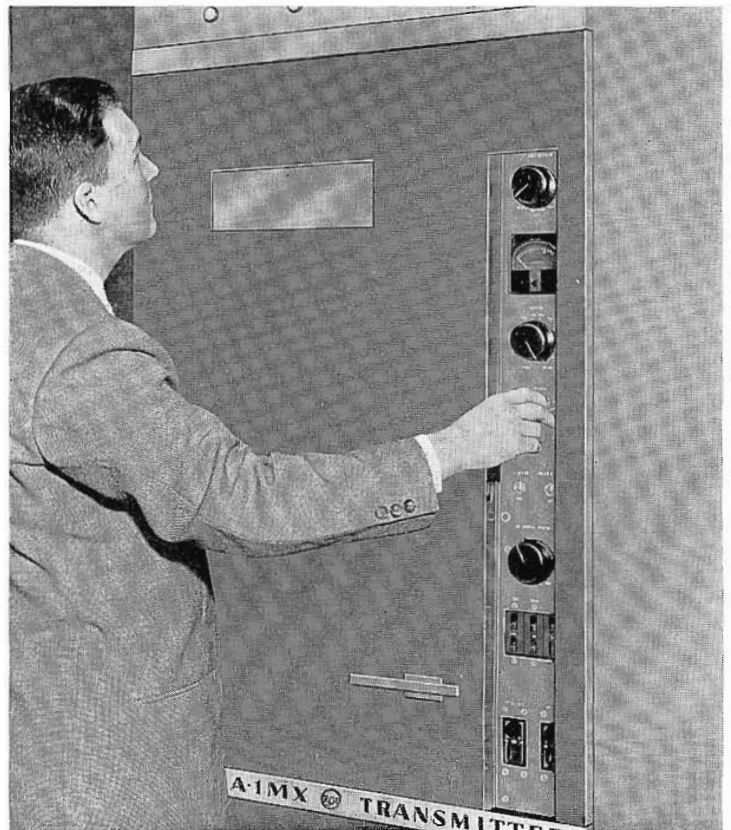

FIG. 1. The BTA-1MX/500MX with all the virtues of its predecessor (BTA-1M) and more. Has bi-level modulation, full enclosure doors for excellent cabinet shielding, improved remote control adaptability. Occupies only 6.2 square feet of floor space.

FIG. 2. Plan view showing dimensions of the BTA-1MX/500MX and adjacent phasing cabinet.

FIG. 3. BTA-1MX/500MX is simple to operate . . . only one tuning control on functional vertical control panel.



have found the low distortion and wide-range frequency response in RCA AM transmitters of recent manufacture more than satisfactory for such critical fidelity requirements. The new designs, moreover, represent additional improvement in both frequency response and distortion.

Average distortion, from 50 to 10,000 cycles, measured in ten production transmitters, did not exceed 1 per cent. At 15,000 cycles, distortion measurements on these

FIG. 4. Front view of BTA-1MX/500MX, doors removed, shows overall simplicity of component arrangement.

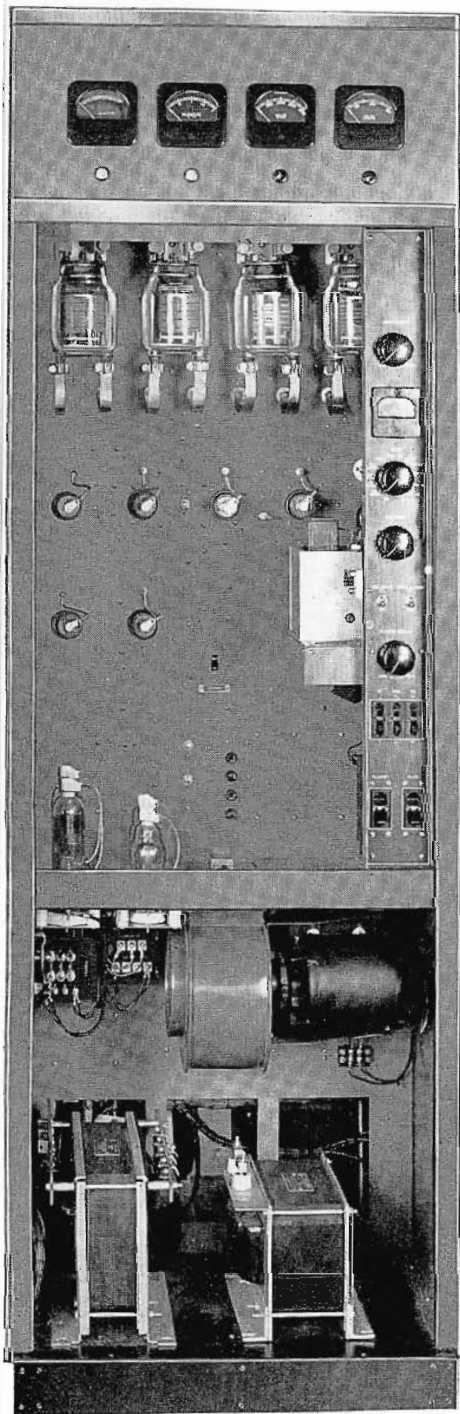

units averaged 1.7 per cent. Similar measurements of frequency response on production units provide an average curve flat within ± 1 db between 30 and 15,000 cycles.

While the frequency response of the new BTA-1MX/500MX is excellent, the new clarity and crispness of program material provided with these units are considered to be related more to the low distortion percentage than to the extended frequency range.

Typical carrier shift, measured on production transmitters, is $1\frac{1}{2}$ per cent.

An unusual characteristic of the design is that it is rated to provide full output in continuous broadcast service at altitudes up to 10,000 feet. While most broadcasters operate well below this range, the safety margin on insulation and on air flow indicates the conservative design parameters around which the new equipment is produced.

Complete vertical construction, long a "must" in RCA transmitter design, is utilized. Every component, front or rear, is instantly accessible for replacement or visual inspection. Soldering to a vertically mounted component presents no gravitational problem.

Power consumption, at one kilowatt output, is only 3500 watts, modulating at 30 per cent with tone. Only 4250 watts (at 90 per cent power factor) are required for full 100 percent modulation.

A single tuning control in the P.A. plate circuit alone is required for normal adjustment in the BTA-1MX/500MX. All other R.F. circuits are broadband. In some cases, Conelrad shifting may be accomplished by crystal switching and P.A. touch-up. At most, a few taps are all that need changing to transfer to Conelrad frequencies.

Electrically, the new transmitters are quite similar to the BTA-1M/500M equipments, of which over one hundred are already in operation.

Mechanically, however, the "MX" equipments have a distinctive 1956 styling which sets them apart from their predecessors. Full-enclosure doors, front and back, provide a high degree of shielding to minimize cabinet radiation.

The transmitters are somewhat smaller than their predecessors, measuring approximately 27 inches wide, 33 inches deep and 84 inches in height.

Bi-level modulation, a noteworthy advance in broadcast technique, first offered

in the preceding design, is continued in the new 1MX series. Only with this method of boosting R.F. drive on peaks of modulation could distortion be maintained at the minimum percentage possible due to this exclusive RCA feature.

In all, the BTA-1MX/500MX transmitters provide, to the AM broadcaster, a fine-performing, functional equipment designed to meet the mode of modern transmitter operation.

FIG. 5. Rear view of BTA-1MX/500MX, door removed, shows precise wiring and full accessibility to components.

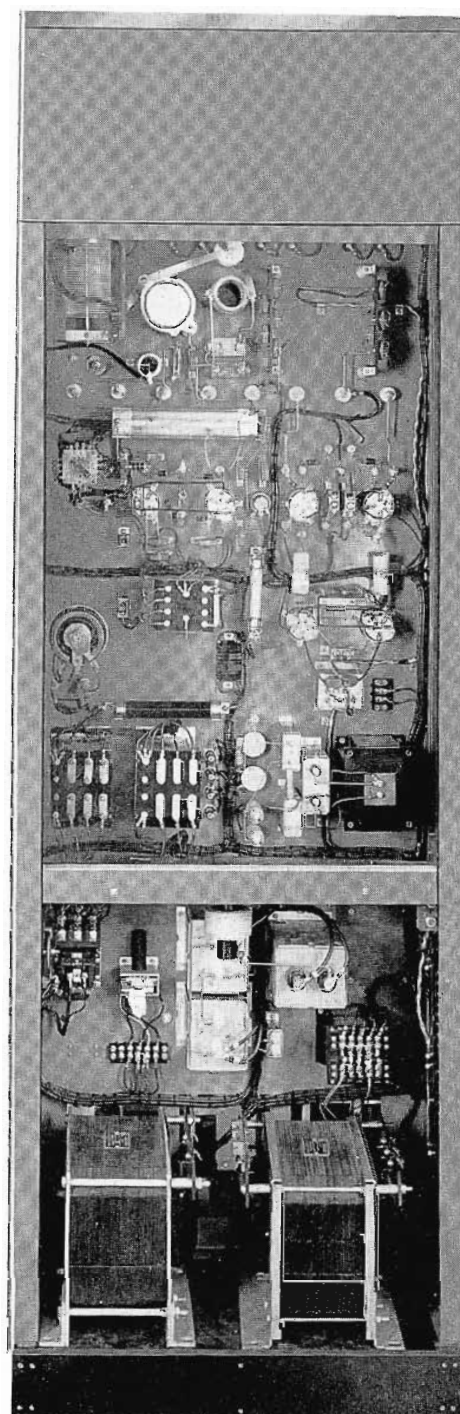



RCA Vidicon Film Cameras installed in the WAAM-TV projection room. Savings afforded in conversion permit the use of two independent film chains for ease of operation as well as provision for preview and auditioning. When the equipment was purchased, the projection room was rebuilt to provide space for both monochrome and future color film equipment.

WAAM-TV CONVERTS FROM IKE TO VIDICON

New RCA Vidicon Film Cameras Are Installed Using 16mm Projectors, Telop, Master Monitors, Console Housings and Power Supplies from Previous Iconoscope Chains

by BEN WOLFE
Director of Engineering
WAAM Television

Two RCA Iconoscope film camera chains were used at WAAM-TV from November, 1948 to December, 1954. During the ensuing years many changes were made to the original circuitry to provide for a better signal-to-noise ratio, improvements in the

overall frequency response, back lighting and edge lighting. Several of the industry's new Iconoscope preamplifier circuits were examined and the one suggested by RCA was built. This particular preamplifier was susceptible to spurious oscillations at times, but with some added degeneration it seemed to be quite stable. The new preamplifier provided a definite increase in signal-to-noise ratio coupled with increased sensitivity. The low, mid, and high fre-

quency response characteristics of the Iconoscope chains were modified and adjusted for improvement. New edge and back lighting were installed in order to secure optimum film performance. While the Iconoscope chain was producing an improved picture, better gray scale or transfer characteristic and a still further increase in signal-to-noise ratio was desirable. In addition, the shading problem was not reduced when film density and contrast varied rapidly.

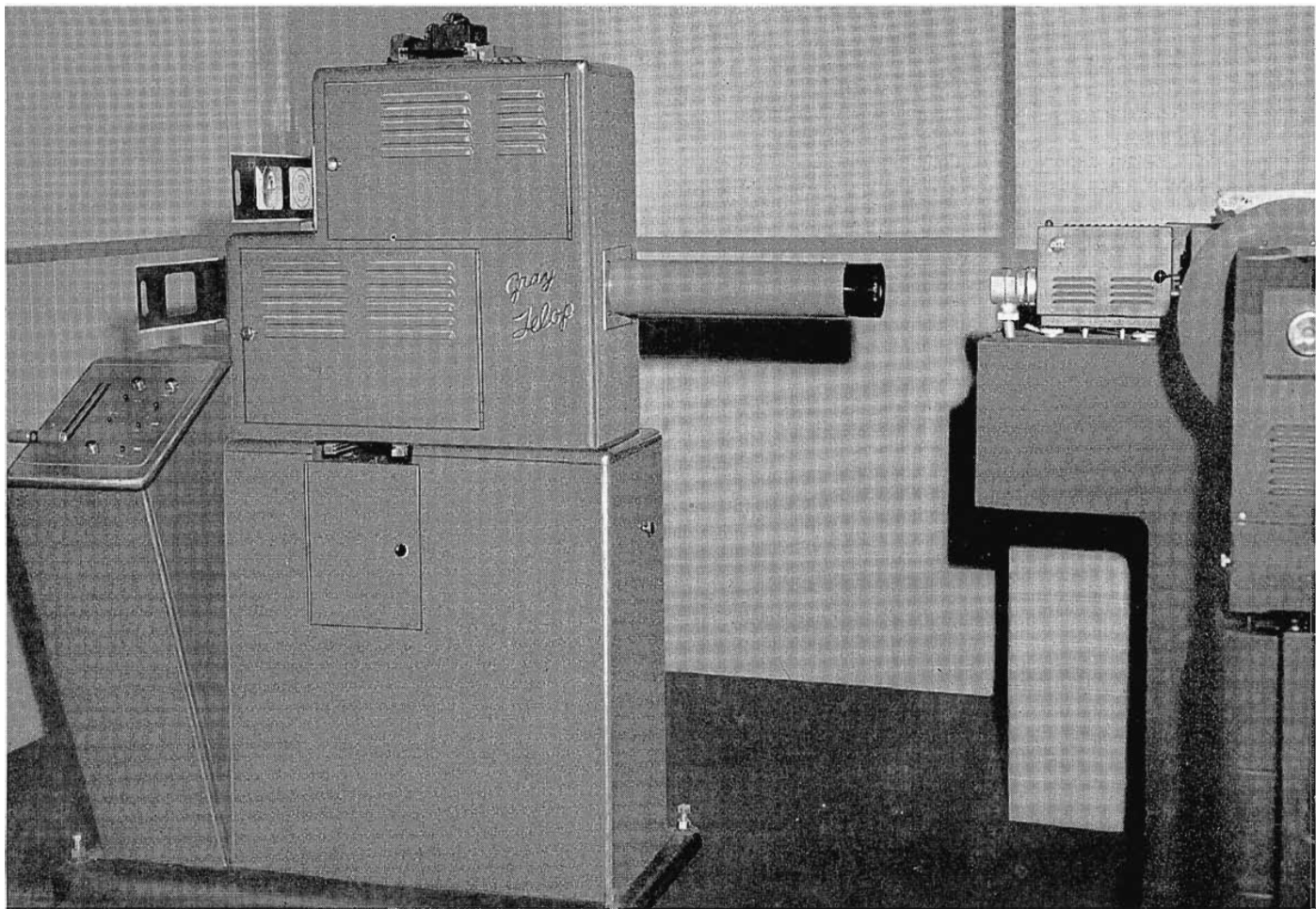

A Telop I, formerly used with one of the iconoscope chains, is directed into one of the TP-11 Multiplexer inputs. In order to use the Telop with the TP-11, it was necessary to fabricate a new lens mount. Details of this revision can be found in the text.

Projector control desk and one of WAAM-TV's vidicon film cameras in the projection room. Projector remote control panels are contained at the desk position, while the remote camera controls and master monitors for each of the chains are located in the master control room.

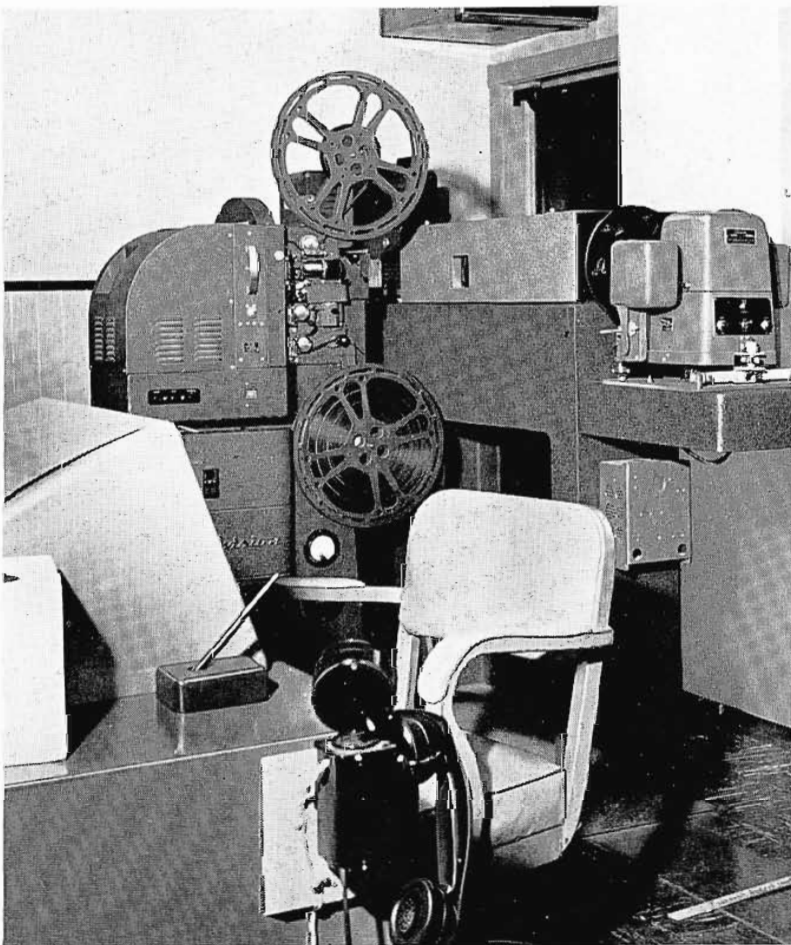

Vidicon Performance Investigated

In late 1953, several papers were released on the RCA Vidicon film camera. In the early part of 1954, the Vidicon chain was viewed at RCA engineering laboratories in Camden, New Jersey. It revealed a definite improvement in gray scale or transfer characteristic, as well as a marked improvement in signal-to-noise ratio. This improvement permitted the manufacturer to employ aperture response correction with corresponding improvement in horizontal resolution. Other improvements were discussed at the laboratory demonstration. The included the wide range of film that could be reproduced due to the high transfer or gamma characteristic and to the constant character of the signal output—light input characteristic, the light source requirements, the elimination of electrical shading cancellation signals and the provision for automatic black level control.

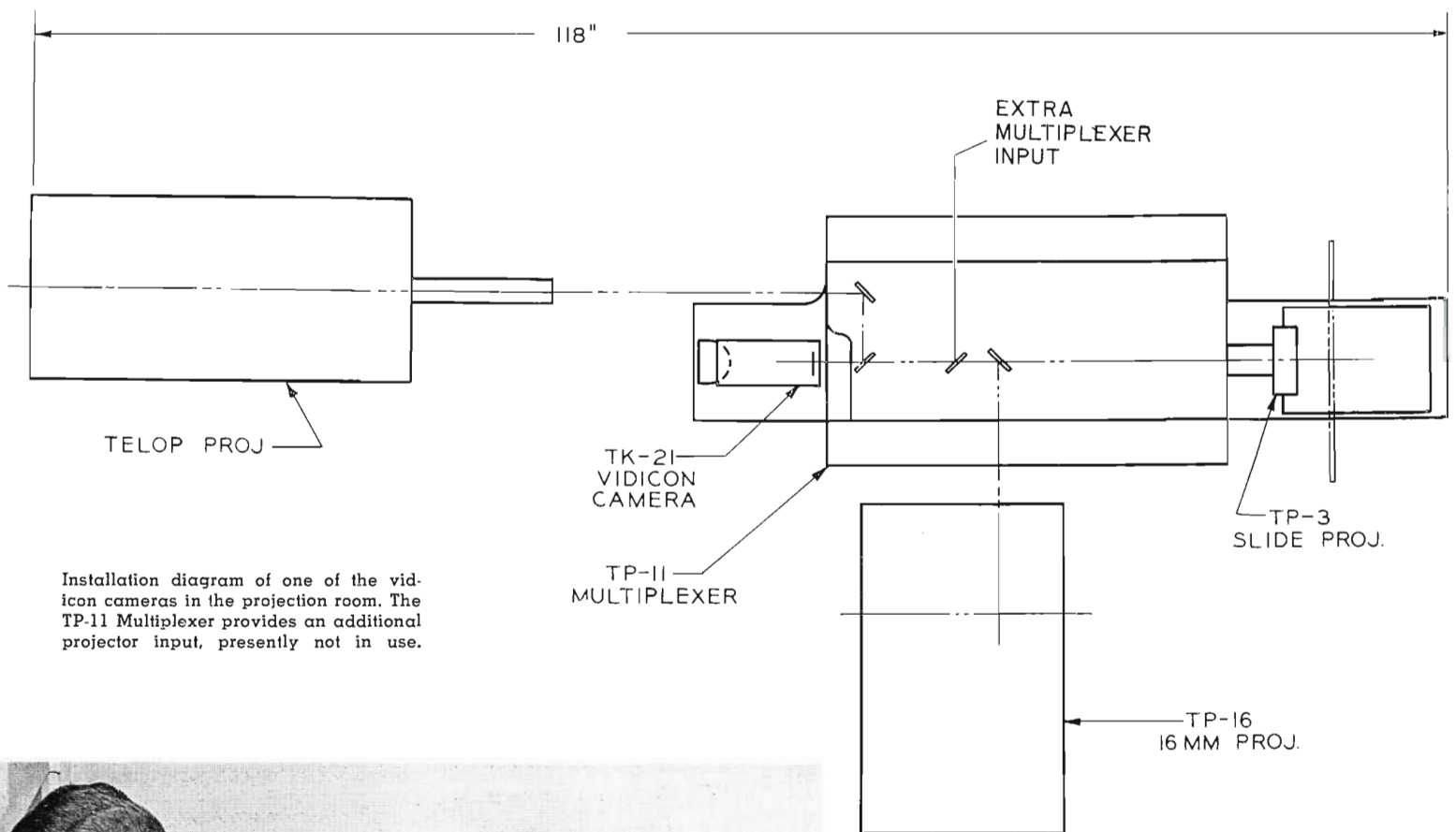

Installation diagram of one of the vidicon cameras in the projection room. The TP-11 Multiplexer provides an additional projector input, presently not in use.

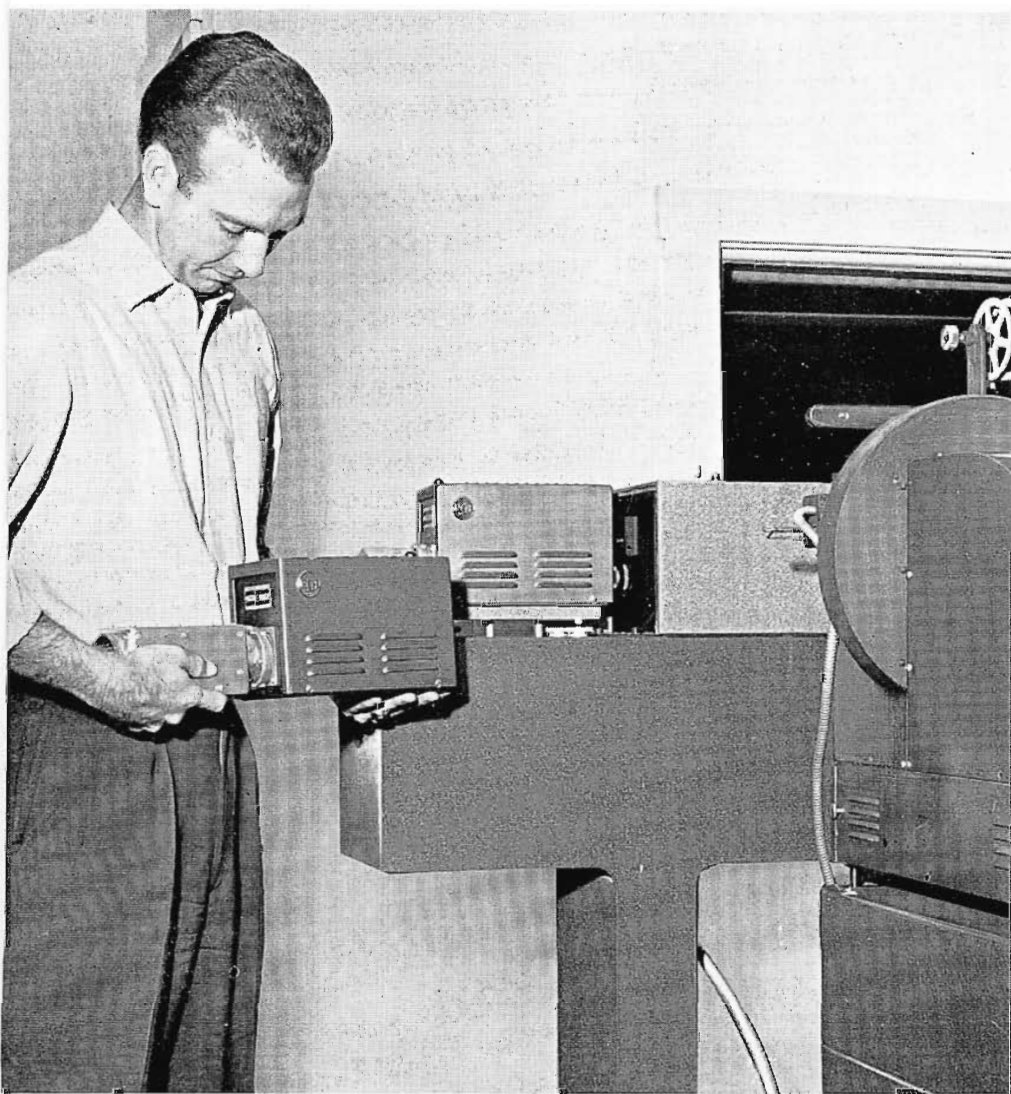

A complete vidicon camera chassis was ordered as a spare. This allows either of the film chains to be quickly returned to service in emergencies.

The Vidicon chain was balanced against our Iconoscope chain by checking the film performance of several prints on our Iconoscope chains and on the Vidicon chain in Camden. The reproduction of the Vidicon chain was superior in each instance, and with a minimum of operating effort.

Conversion Equipment Installed

In December 1954 and February 1955, two Vidicon chains were installed at WAAM, complete with two TP-11A multiplexers. The arrangement is such that a TP-16 projector and a 35-MM slide projector are directed into each TP-11A multiplexer. After the TP-16 film projectors and the TP-3C slide projectors were installed, some thought was given to using the Gray Telop I which was formerly used with one of the Iconoscope chains. In its original use the Telop was fitted with an $f 4.5$ lens of 18-inch focal length. Since the Iconoscope mosaic measured $3\frac{3}{4}$ by $4\frac{1}{2}$ inches the projected image size was roughly that of the object size. This was undesirable for Vidicon use as the projected image size was too large for the multiplexer. Since the object and image sizes were approximately equal, it was reasoned that the object distance must be in the neighborhood of twice the focal length. Therefore this distance

should be increased, because with a converging lens and an object at a distance of greater than twice the focal length, the image is real, inverted, and smaller than the object. Accordingly, the lens was removed from its mount and it was found that placing it approximately 18 inches from the front of the Telop gave a proper sized image. A new lens mount was fabricated in the engineering shop using 4¼-inch o.d. by ⅛-inch wall brass tube 18 inches long. It was necessary to bore out the inside diameter of the tube 1/32 inch to take the lens. The tube was mounted to the Telop by hard soldering it to a piece of 6 by 6 by ⅛-inch brass sheet. The brass sheet and tube used are stock mill sizes and should be obtainable from any brass and copper distributor. After trying the lens in its new mount, the assembly was removed and the interior given a coat of flat black to reduce internal reflections and the exterior given a coat of zinc chromate primer and then umber gray to match the other projection room equipments.

Savings Realized by Using Existing Auxiliary Equipment

While the TP-11A multiplexer was designed to accommodate two 16-MM film projectors, a 35-MM slide projector and an opaque projector, it was felt that the econ-



Controls for the vidicon chains are located here in the master control room. The second and third monitors from the left are the vidicon master monitors. Their housings also enclose the camera remote control panels. Both master monitors and console housings are part of the station's original iconoscope equipment.

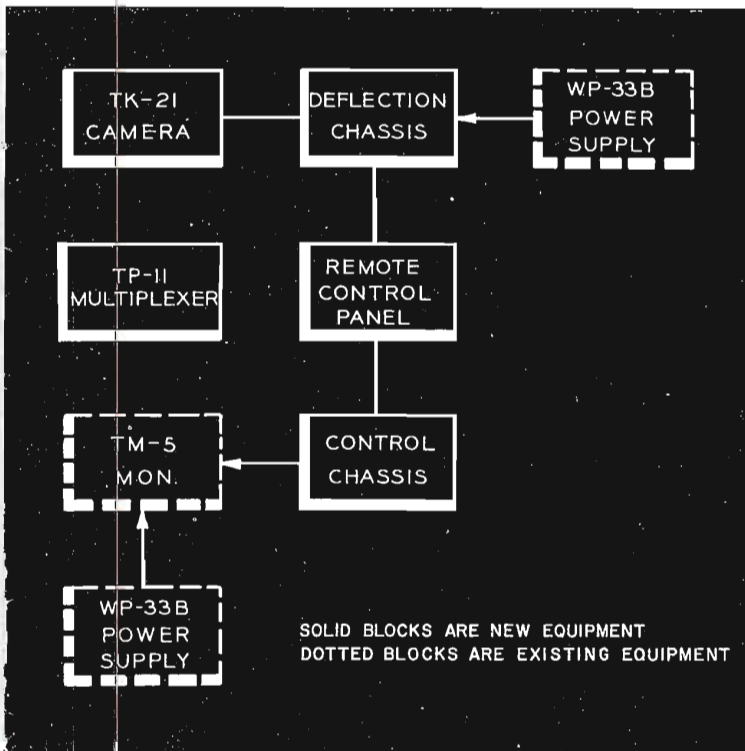

Functional block diagram of WAAM-TV's vidicon camera equipment. Equipments show in solid lines were the only new items required for conversion of each film chain. In addition to the existing equipment shown in dotted blocks, the station was also able to use their original projectors and console housings.

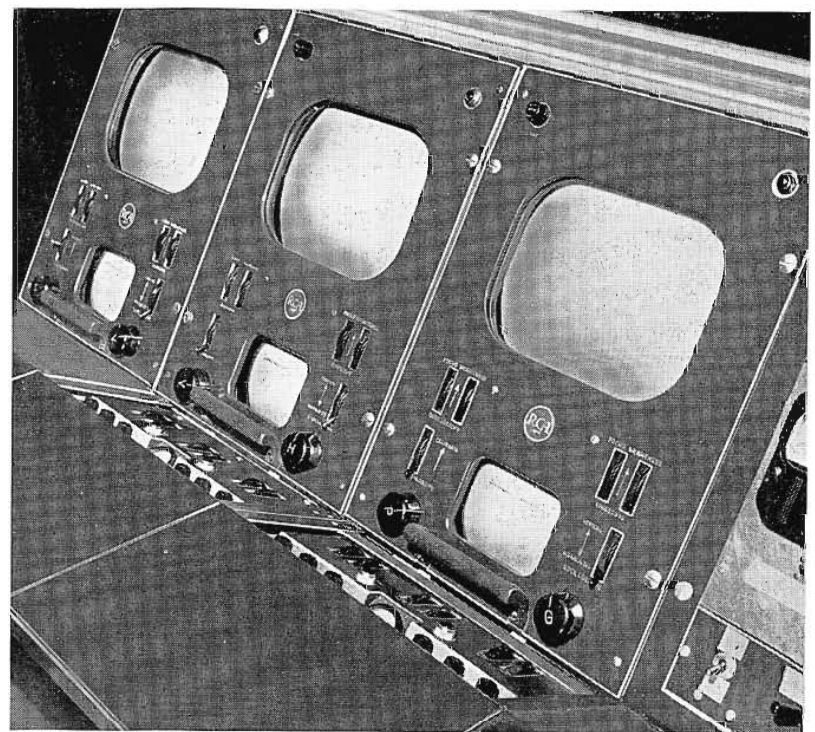

Closeup of the vidicon master monitors in their control housings. Use of existing equipment greatly simplified the installation. No changes in arrangement were required in the master control room. Vidicon remote control panels were substituted for the control panels of the iconoscope cameras. Auxiliary iconoscope equipment previously mounted in the base of the console housings was removed.

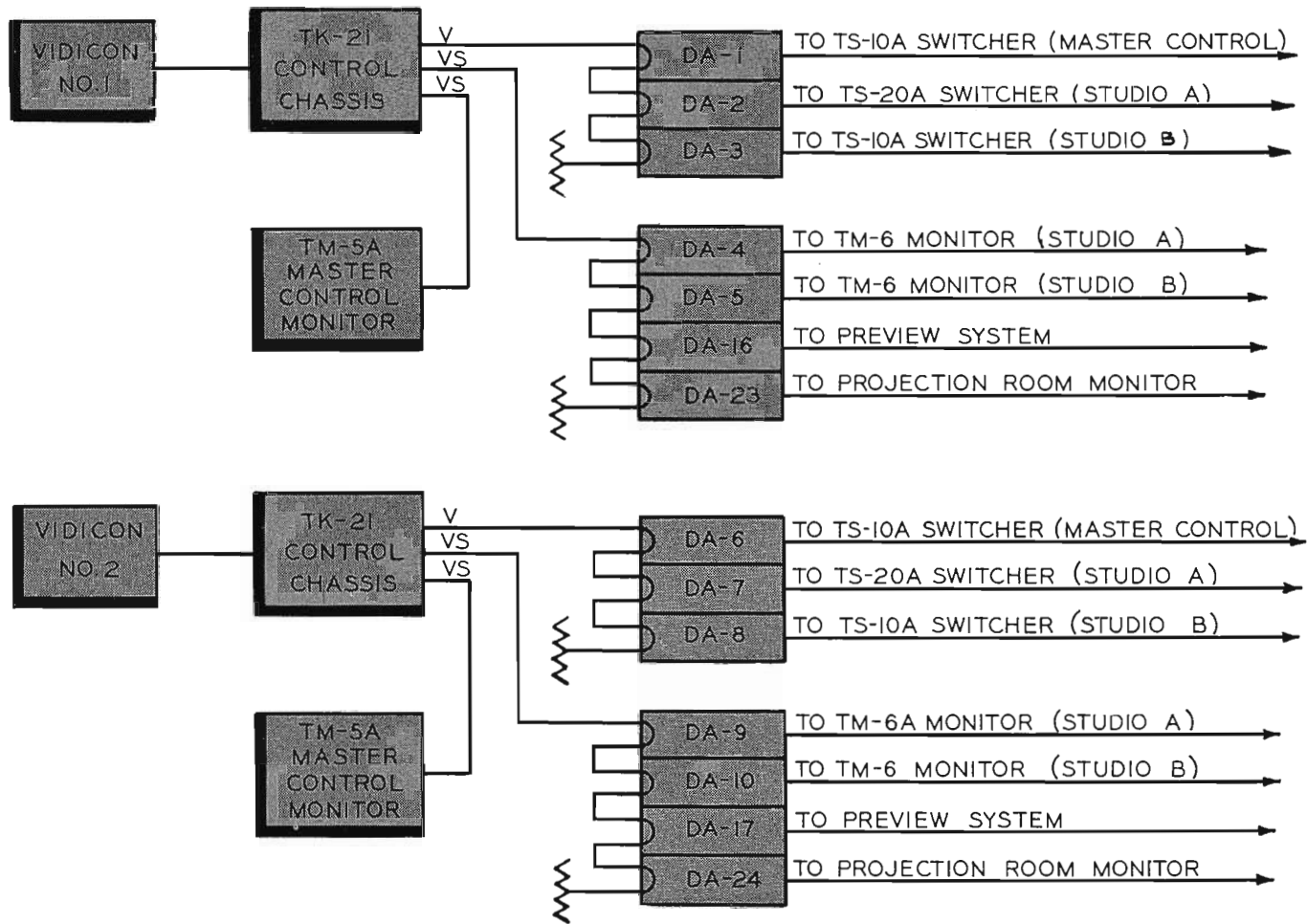

Block diagram showing video distribution of the two WAAM-TV Vidicon film chains.

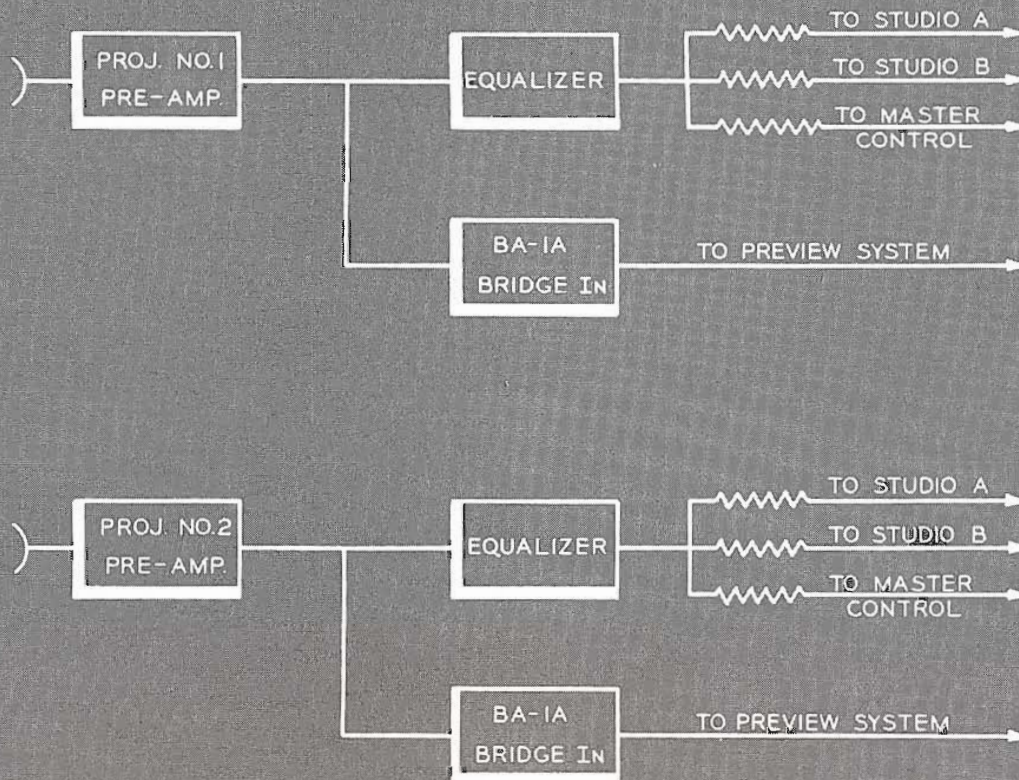

Block diagram showing distribution of audio from the two TP-16 projectors associated with the vidicon film chains.

omy afforded us by salvaging the auxiliary equipment (master monitors, console housings and WP-33A power supplies) of the Iconoscope chains, permitted the use of two multiplexers with two Vidicon chains. This plan permitted ease of operation and provided preview and auditioning. A block diagram showing video distribution of the film chains to Master Control, Studio A, Studio B and Preview is shown. A similar diagram is furnished for audio distribution.

At the time the Vidicons were purchased, the projection room was completely rebuilt to provide space for color film equipment as well as Monochrome Vidicon chains. The Iconoscope chains were left in place while the room was being rebuilt. This permitted almost complete physical installation of the Vidicon chains and multiplexers without disturbing the operation of the Iconoscope chain. The TM-5A Master Monitors associated with each of our Iconoscope chains and their console housings were used for the Vidicon chains. The Vidicon remote control unit was mounted in the sloping section of the console housings. Two racks in our Master Control room each house the Vidicon deflection unit, the Vidicon camera control chassis and their associated WP-33A power supplies. The installation of the major portion of the Vidicon equipment in Master Control affords quick servicing by the technician on duty as well as continuous observation of the chain's performance.

Ad Agencies Applaud Improved Picture Quality

The two Vidicon chains have been in operation a little less than a year, and the results have been highly satisfactory. This should not be interpreted that the Vidicon is a "cure all", for if extremely poor quality film is used, Vidicon reproduction will be poor as with all systems. However, the system does provide a minimum of deterioration in the transmission of the optical information for the video signal. The video signal output of the Vidicon using the Telop is approximately equal to that of the slide and film projectors. In addition, the comments from various advertising agencies have been gratifying. The improvement in reproduction fidelity, gray scale reproduction, signal-to-noise ratio and operational stability provide the basis for these comments.

In conclusion, the writer wishes to acknowledge the cooperation of G. Lahman, Chief Engineer and M. P. Johnson, Facilities Engineer in the installation, setup and performance proof of the Vidicon chains.

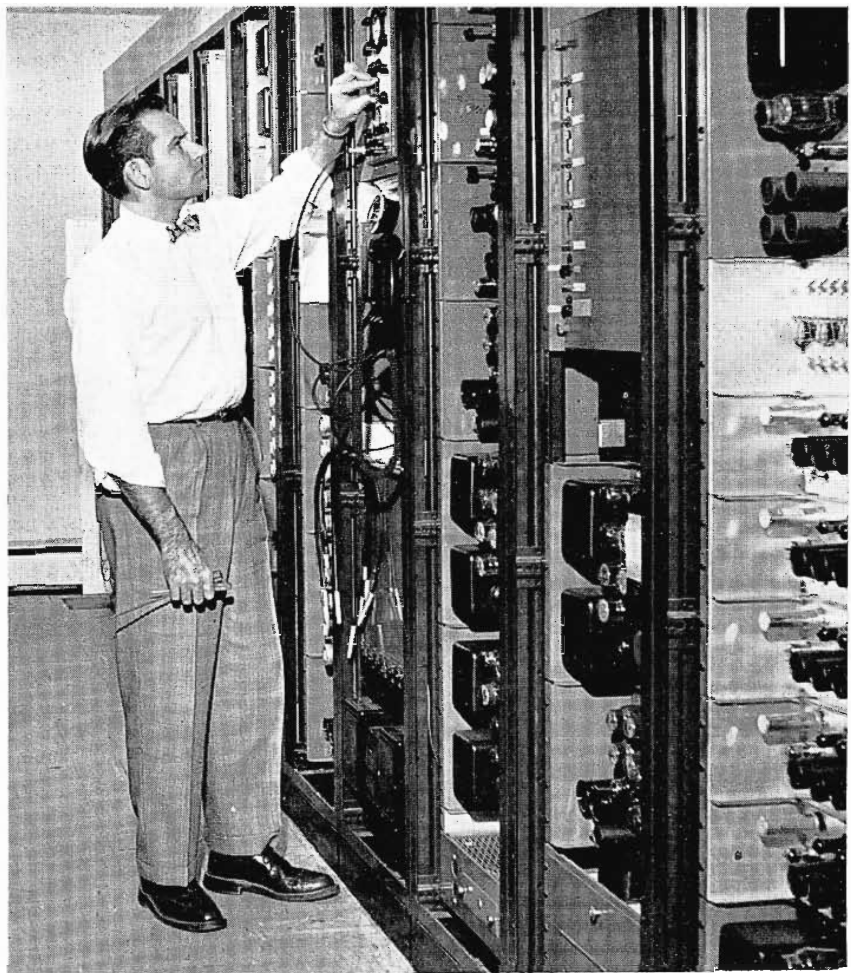

Another view of the master control room showing placement of equipment racks, which are readily accessible to the control operator for setup and maintenance.

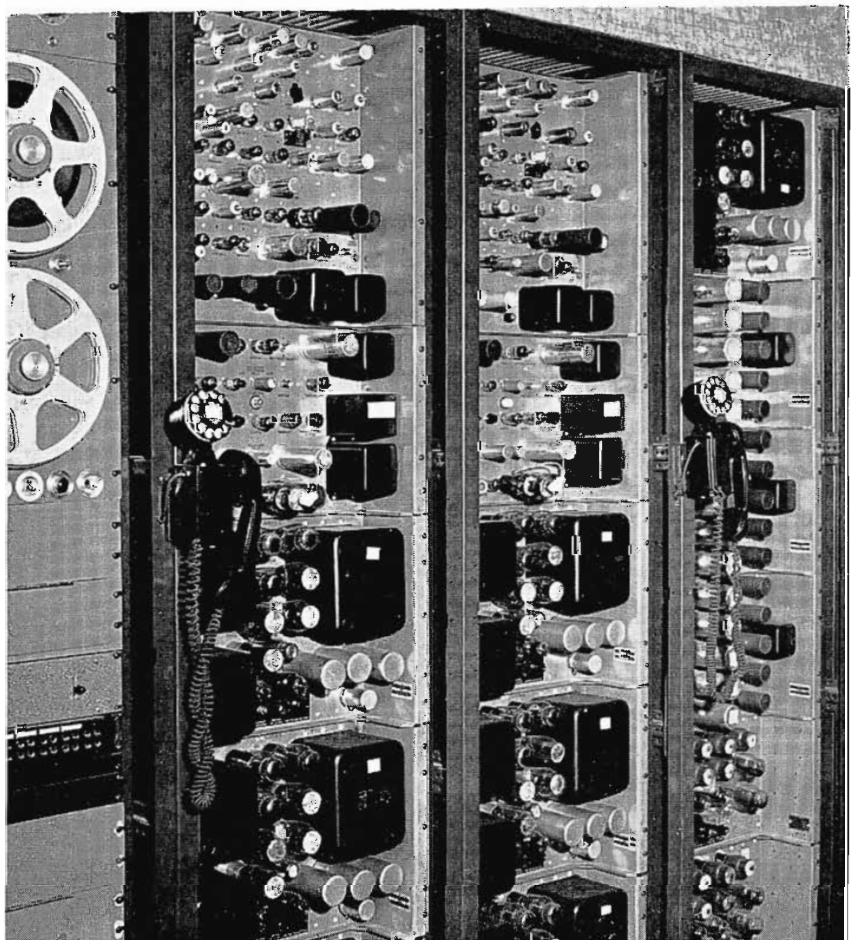

The center two cabinet racks contain auxiliary and power requirements. Each rack contains (top to bottom) the vidicon control chassis, the vidicon deflection chassis and two WP-33B power supplies necessary for operation of the film chain. The other WP-33B power supplies are used for operation of other equipments.

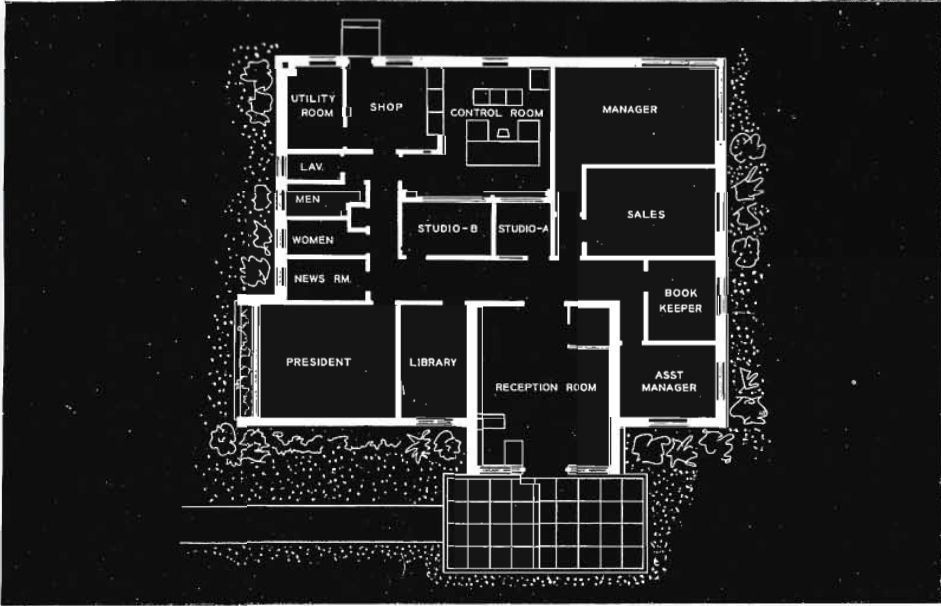
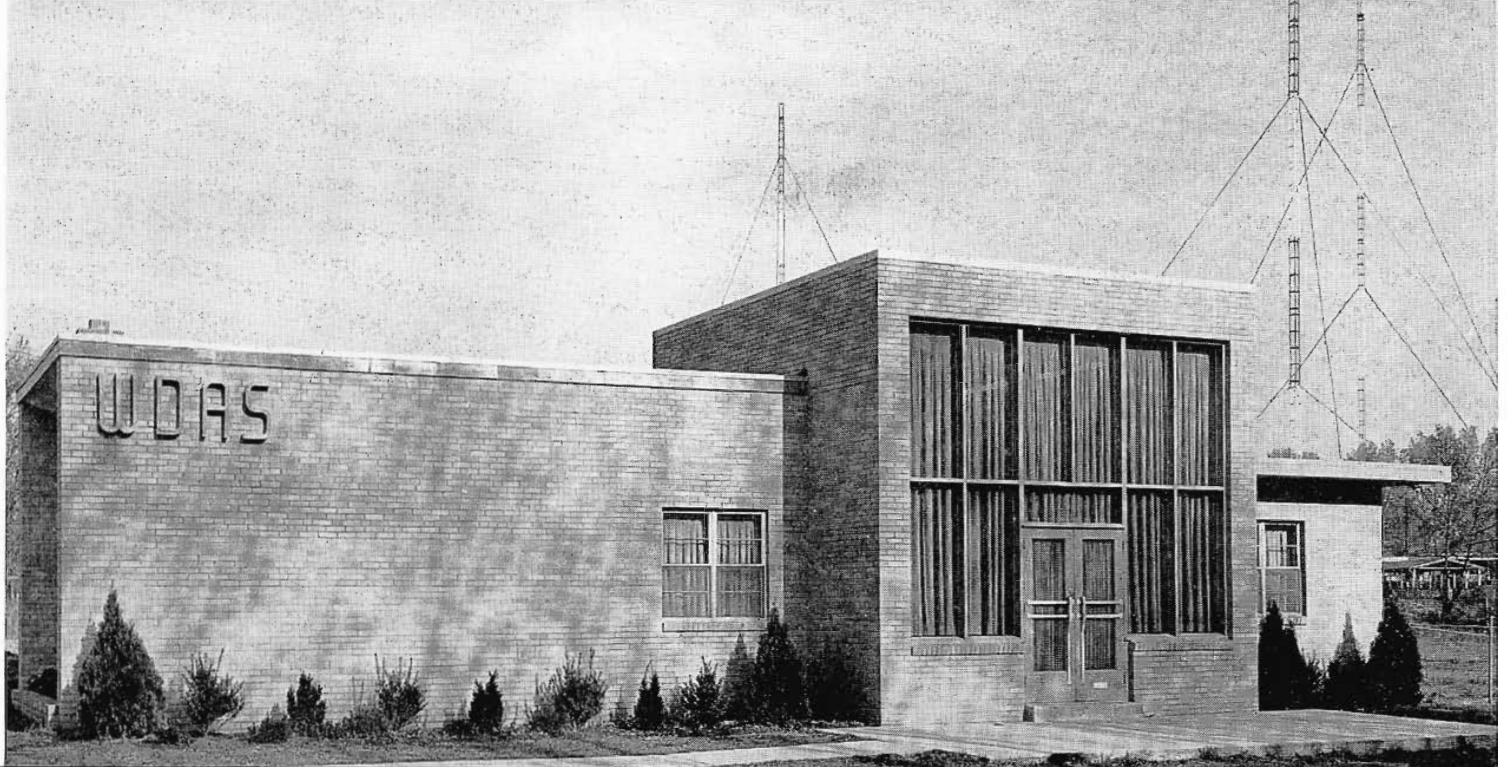

FIG. 1. The new WDAS combined Studio/Transmitter building is functional as well as attractive. Interior arrangement is shown in floor plan at left. Details of construction are described in text.

WDAS

PHILADELPHIA'S OLDEST INDEPENDENT GOES HIGHER POWER AND HIGH-FIDELITY

Since 1922 this station has been a Philadelphia "landmark"—serving Greater Philadelphia and the Delaware Valley Area including portions of South Jersey and Delaware. Although other stations have assumed network affiliations, WDAS has maintained its status as Philadelphia's oldest independent.

WDAS is owned and operated by Max Leon who also is the Conductor of the Philadelphia Pops Orchestra. Mr. Leon's appreciation of fine music has been a factor in selecting broadcast equipment capable of high-fidelity operation in addition to higher power for blanketing the coverage area with adequate signal strength.

FIG. 2. Max Leon, President (center) discusses future plans with Bob Klein, Station Manager (left) and Leonard Matt, Assistant Station Manager.

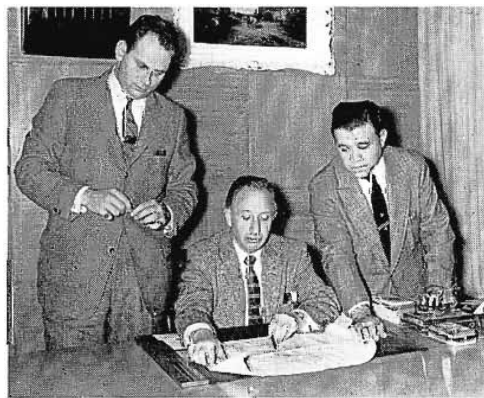

After growth which involved installation of progressively improved equipment and moves to different locations, WDAS has now located its station on a spacious plot of 10 acres near the northwest city line. The site features a magnificent new building (shown above) and can be spotted from miles around by a group of five towers which form the directional array.

The move to the new site included a move to higher power—250 watts to 1 kw—and a move in frequency from 1400 on the dial to 1480.

The Building

The building is a one-story slab-on-grade structure of all-masonry construction with

a concrete floor. It measures 60 feet by 60 feet. The walls are cavity type construction with a buff brick exterior and cinder block interior with a 2-inch dead air space in between. The smaller windows throughout the building are double-hung aluminum sash with panes of double glass separated by 1/2-inch dead air space in between. The dead air space minimizes penetration of external heat from the sun. The large decorative window at the main entrance is green tinted heat-absorbing glass which filters out infra red, also serving to maintain a cooler building in warm weather.

The ceilings are constructed of fibreglass panels suspended in aluminum inverted T's. The ceiling material in addition to being fire proof provides excellent insulation and acoustical properties. It is easily removed to gain quick access to wiring. Except for the studios and some of the offices, the building interior walls are exposed cinder block painted in pastel colors. The president's office is finished in Philip-

pine mahogany paneling. The main building structure is completely fire proof. The building, in addition to its attractive styling, conveniences and safety features, contains a functional combined transmitter/studio layout, affording full efficiency of operation, which makes the normally heavy program schedule easy to handle. More than ample room is available for building expansion which is planned for the future.

Studios and Studio Control

The studios and control room are equipped with RCA microphones, turntables and an RCA 76B Consolette which bears the heavy program traffic with traditional ease and dependability. Studio "A" (see Figs. 1 and 3) is wired with three "mike" receptacles which are connected to a jack field in the audio rack and normalled through to the consolette. Studio "B" also has three mike receptacles connected to the jack field, two of which are normalled to the consolette and the third mike position available to consolette control by patching.

A mike circuit is available in the reception room to accommodate groups too large for the other studios. Each studio has an RCA turntable which announcers can use to play their own records.

The studio control area and transmitter area are directly adjacent, being divided only by their respective positioning. This affords a view of all operations and requires minimum personnel during off-peak hours.

Equipment in the control room consists of an RCA 76B Consolette with power supply, two RCA 70C1 Turntable adapted for playing 45 rpm records, one RCA BQ-1A Fine Groove Turntable for 33 and 45 rpm records and a separate RCA 70C1 with a cutting head for disc recording. For studio/control room talk-back use an RCA 88-A Announce Mike is mounted atop the 76B Consolette. Many of these audio items are equipment which have been in use for many years at WDAS—proving the durability of RCA Broadcast Products.

FIG. 3. View of studios and studio control. Studio "A" on left and Studio "B" on right. RCA 76B audio consolette (foreground) has given WDAS many years of dependable service.





FIG. 4. RCA BTA-1M 1 kilowatt transmitter, left, with power dividing and branching equipment mounted in two matching right wing phasing cabinets. Day/night switching facilities are in cabinet directly to right of BTA-1M.



FIG. 7. Frank W. Unterberger, Chief Engineer—with WDAS since 1929.

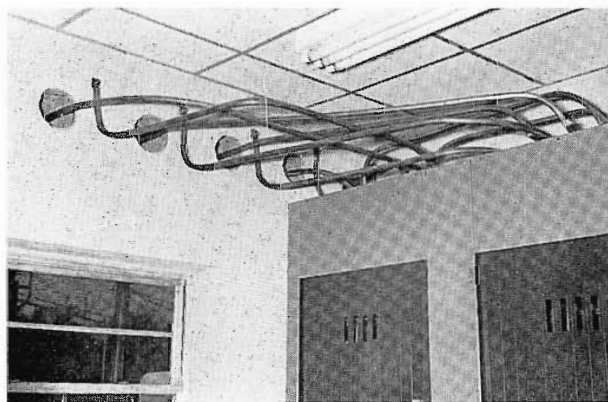

FIG. 5. View showing transmission line feed to feed-thru insulators. Lines fastened directly to wall connect through to ground plates on outer wall.

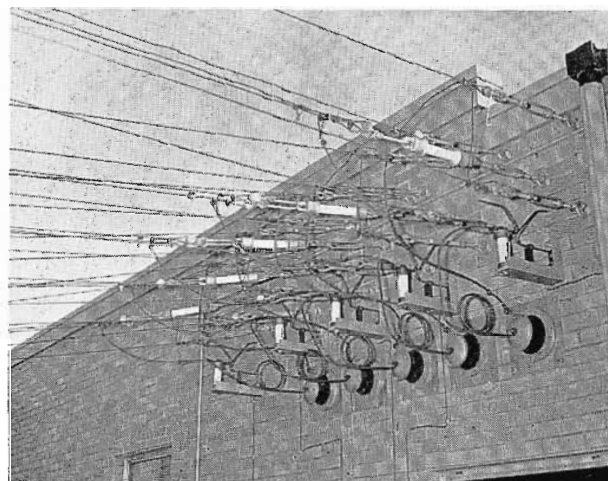
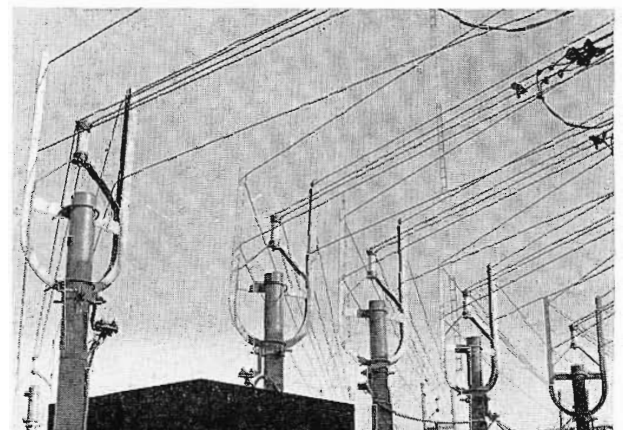

FIG. 6. Building dead-end termination of open wire line leading to five towers. Lightning protector horn-gaps are visible above each ground plate.

Tape Recording, Input and Monitoring Equipment

Three racks located behind the audio console position contain two tape recorders, one RCA 96AX Limiting Amplifier and six RCA 33A Jack Panels for patching in signals from various program sources. Rack equipment consists also of two RCA line equalizers, program monitor and pre-amplifiers. Additional rack equipment consists of one RCA 66A Modulation

FIG. 8. Pole-mounted bayonet insulators support the open-wire transmission line runs. Although not visible these poles also support sampling lines.



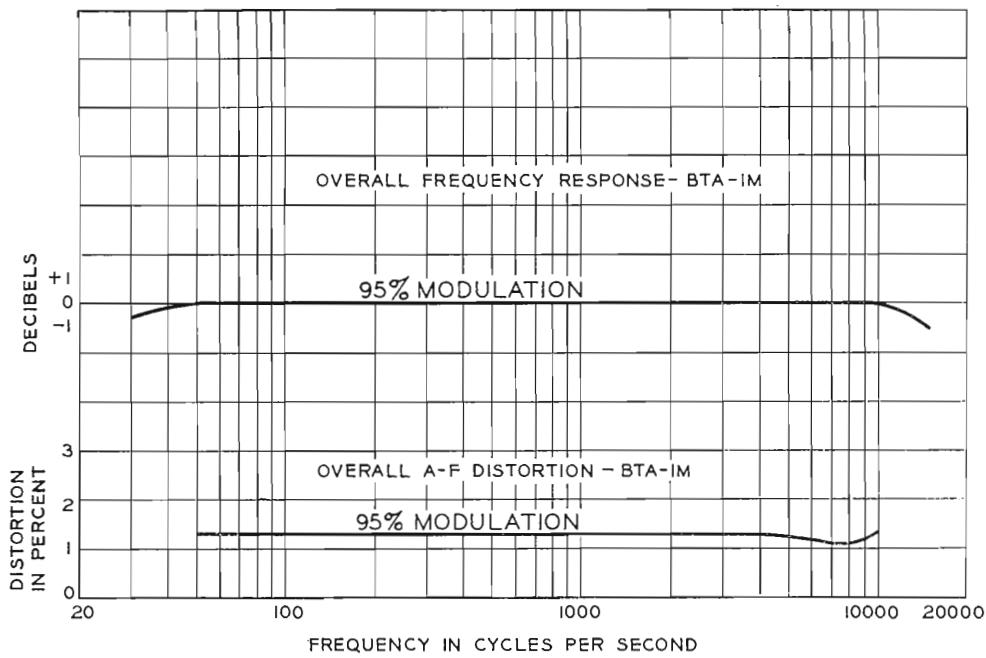

FIG. 9. Response curves show capability of high-fidelity performance from WDAS transmitter.

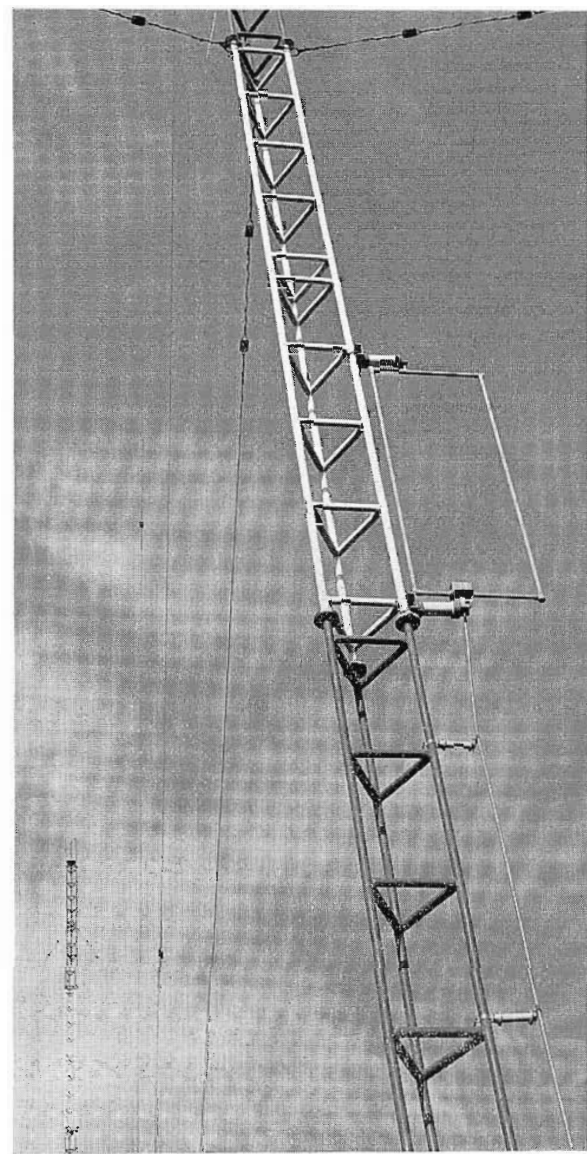

FIG. 10. Close-up of one of five Stainless guyed towers showing sampling loop and sampling line insulated from tower. Tower heights—148 feet—do not require lighting.

Monitor, Phase Monitor type 108-E and an RCA Frequency Monitor EX-4180 which has been in continuous service for 23 years.

Transmitting Equipment and Phasing

Throughout their long history WDAS management and engineering have chosen RCA transmitting equipment exclusively—only recently relinquishing an RCA BTA-250K for a new BTA-1M 1 kilowatt. The new transmitter features bi-level modulation and high-fidelity performance as substantiated by the curve shown in Fig. 9. Two right wing phasing cabinets house power dividing and branching equipment as well as switching facilities for day and night patterns.

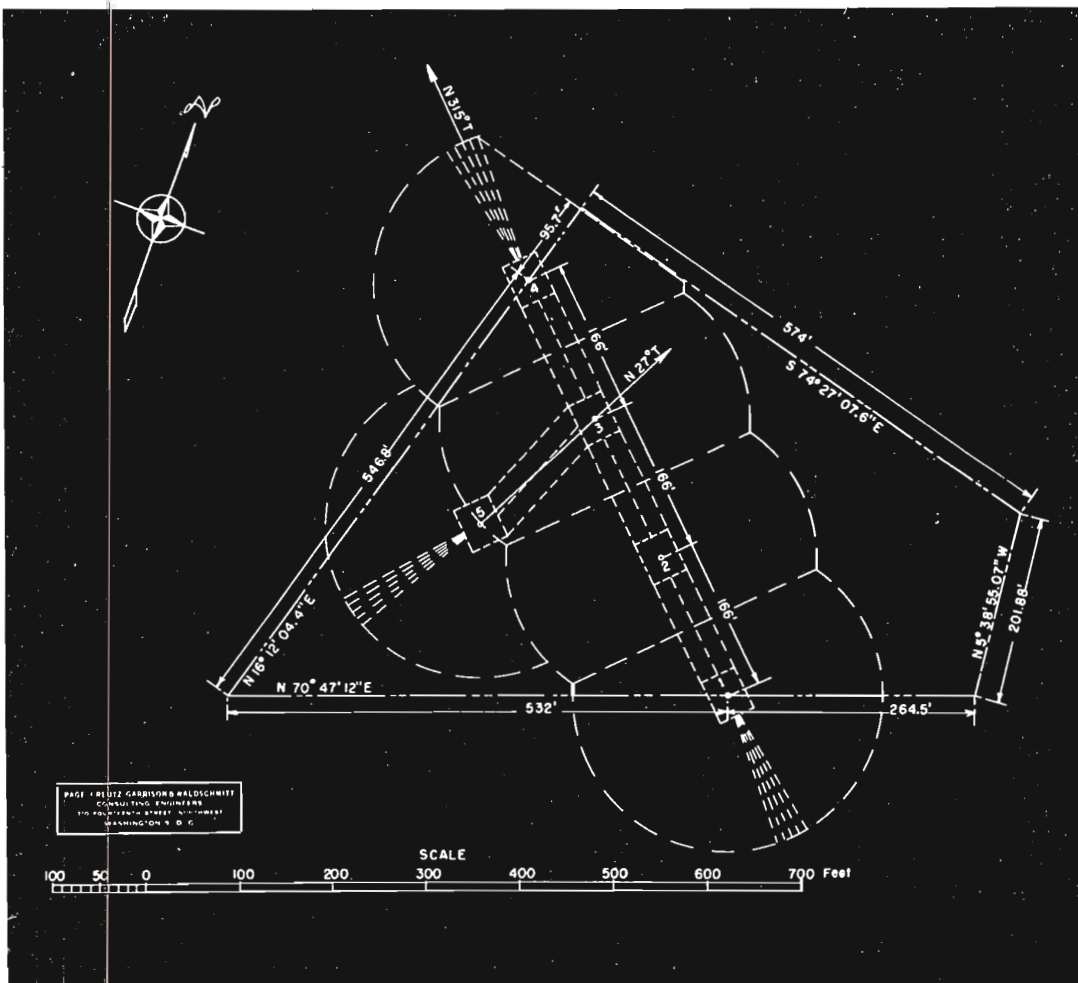

FIG. 11. Antenna locations and ground system. Towers Nos. 3 and 5 used for day operation—Nos. 1, 2, 3 and 4 used for night operation.

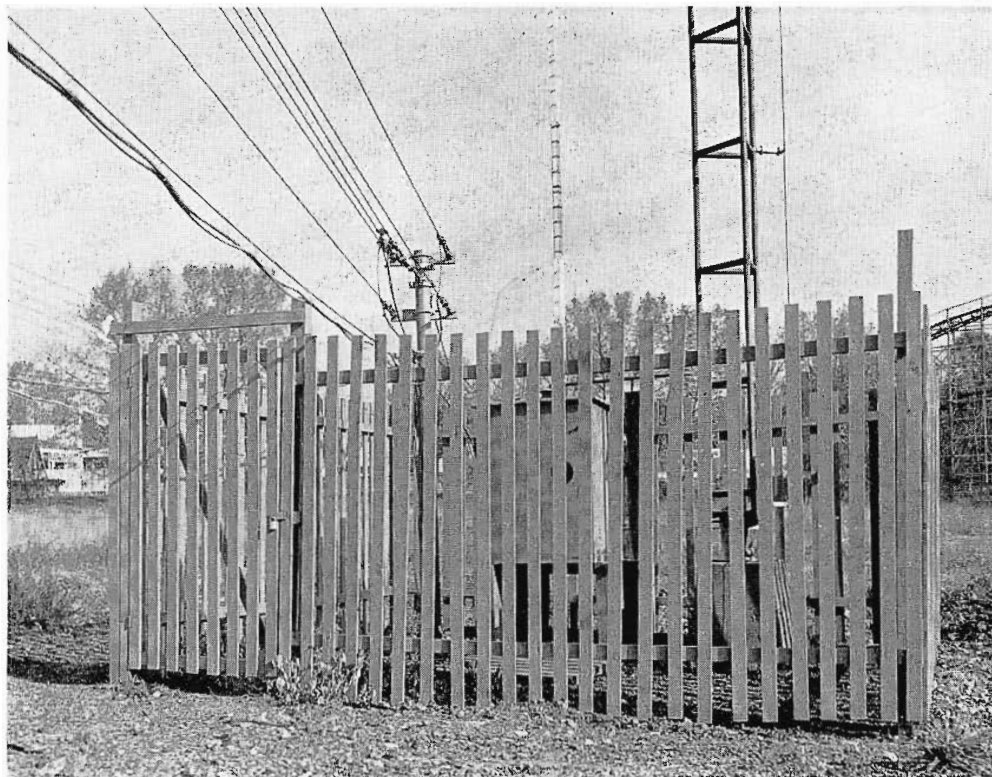

FIG. 12. Base of tower showing transmission line feed to tuning house, sampling line (lower left) and protective fence.

As previously mentioned, a type 108-E phase monitor is rack mounted. This unit continuously monitors the current phase between the various elements of the antenna system. The phase monitor is fed from single turn electro-statically shielded sampling loops located approximately twenty feet above ground and insulated from the towers through doubly shielded solid dielectric transmission lines. (See Fig. 10). The coaxial sampling lines are all of equal physical length and close to

identical electrical length. Five remote meters are incorporated into the 108-E phase monitor to repeat the base current of each tower.

Transmission Lines and Antennas

From the phasing cabinets located adjacent to the BTA-1M transmitter, $\frac{7}{8}$ -inch copper tubing carries the transmitter output power to wall mounted feed-throughs leading to the outside building wall which hold the open-wire transmission line dead-

end termination. (See Figs. 5 and 6.) Supported by bayonet type insulators, open wire lines of 230 ohms lead to tuning units at the base of each tower. Below the "U" bracket of the bayonet insulators sampling lines are supported by the poles on their run to the phase monitor located in the transmitter building. (Figs. 8 and 12.)

Line Terminating Units

Switching relays are located in line terminating units at the base of the tower for changing the day/night patterns—see Figs.

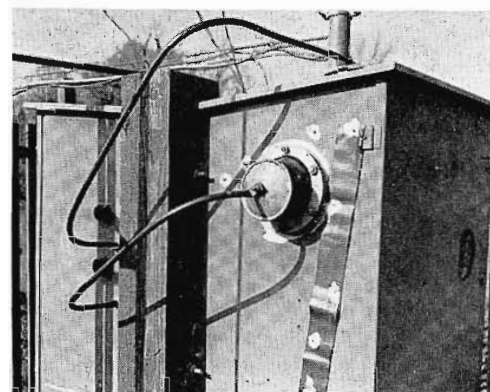

FIG. 14. Tuning houses back-to-back for day-to-night pattern tower.

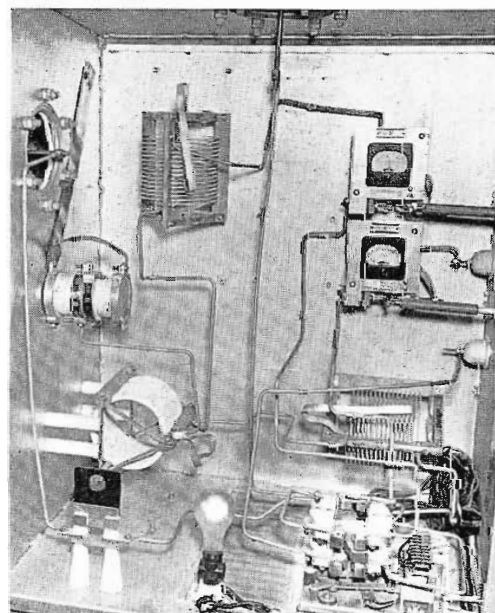

FIG. 13. Line terminating unit interior showing switch for day/night patterns. Two meters are for day current and night current measurement.

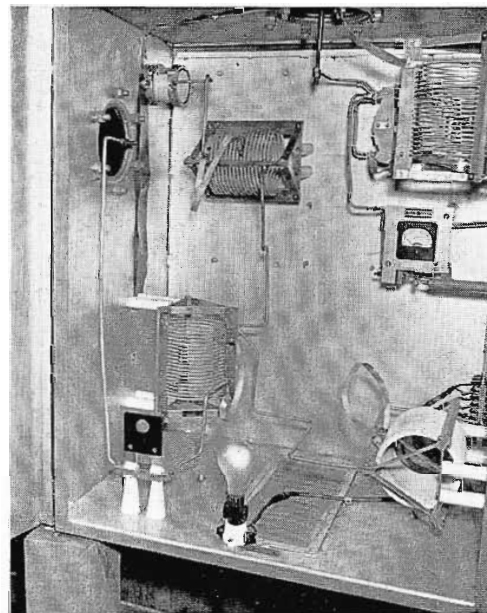

FIG. 15. Interior of LTU. 100 watt bulb keeps down dampness—provides light for reading meter through the door porthole.

13 and 15. These views also show oversized mica capacitors and other components. The light bulb at the bottom of each LTU cabinet serves to remove dampness as well as provide readability of day and night current meters located in the cabinet. The meters are visible through a porthole opening in the LTU door.

Directional Antenna System

The antenna installation consists of five uniform-cross-section guyed vertical steel towers 145 feet in height above the base insulator or 148 feet overall height above ground. Two of these towers (Nos. 3 and 5 as shown in Fig. 11) are used to produce the day pattern and four of the towers (Nos. 1, 2, 3 and 4) are excited to produce the nighttime pattern. The towers being less than 150 feet do not require tower lighting. All five towers are painted throughout their height with alternate bands of equal width. The colors are aviation surface orange and white, terminating with aviation surface orange bands at both bottom and top. The width of each band is approximately 20.5 feet.

Each tower location has a 40 foot by 48 foot copper mesh ground screen and 120 radial wires of No. 10 A.W.G. soft drawn copper 166 feet long except where adjacent tower radials are bonded to a common bus, plus a 3-inch copper strap between towers and the transmitter ground. Radial wires are buried 3 to 6 inches and all connections silver soldered.

WDAS Plans Future Expansion

The accompanying photographs and illustrations give evidence of the fine job of planning and engineering required to expand the facilities of WDAS. Mr. Leon's confidence in the radio broadcast medium and his desire to improve the quality and impact of his service has sparked this aggressive move. Even greater expansion is planned for the future.

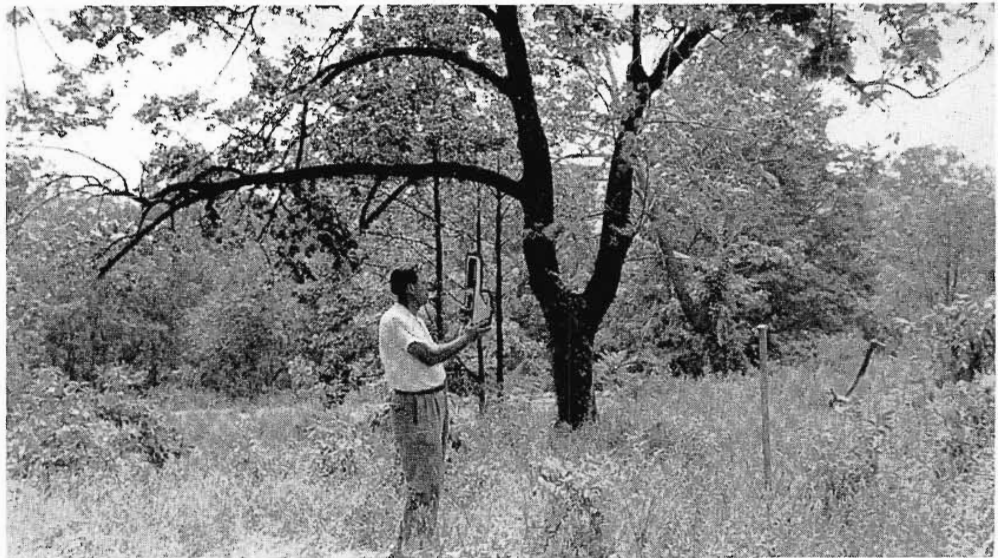

FIG. 16.

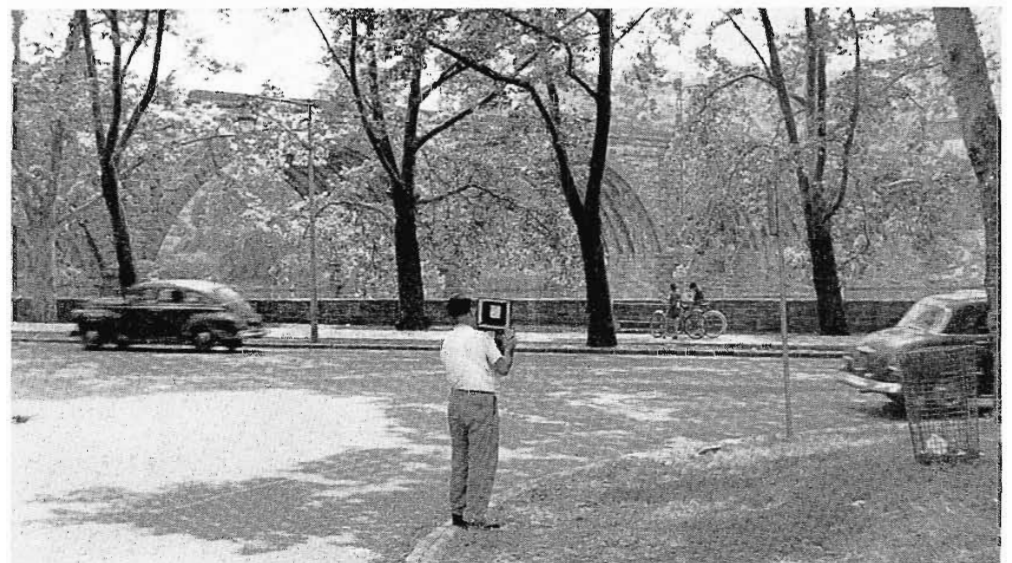
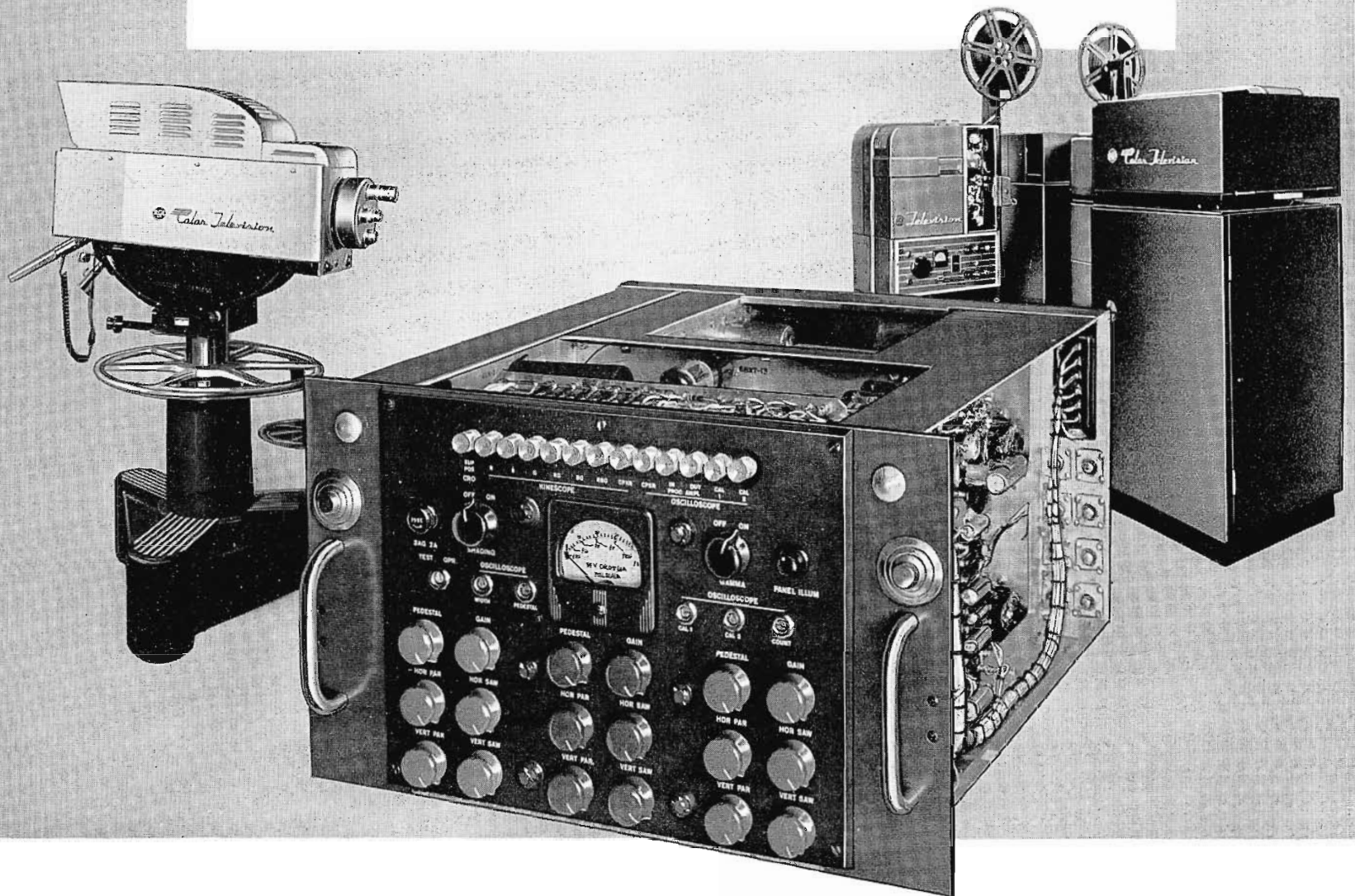

FIG. 17.



FIG. 18. This and the above photos show monitoring point locations selected to monitor the operation of the two directional antenna systems. Chief Engineer Frank Unterberger uses RCA WX2C Field Intensity Meter.

THE PROCESSING AMPLIFIER IS USED FOR BOTH LIVE AND FILM COLOR CAMERA CHAINS



NEW SIGNAL HANDLING TECHNIQUES SIMPLIFY CONTROL OPERATIONS FOR COLOR TV

Technically, color television has made rapid progress from the FCC approval of a compatible color TV system to the design and production of today's station equipment for local color origination. During this time many new techniques have been developed to handle television's "new dimension", that of color information. Significant among these techniques is the development of RCA's processing amplifier which greatly simplifies control operations for color television.

Several operational benefits have resulted from the introduction of this equipment which is used with both the RCA Live Color Camera, TK-41, and the RCA 3-Vidicon Film Camera, TK-26 (see Fig. 1). Most prominent of these benefits is the simplification of equipment needed to operate earlier live color cameras. The processing amplifier has combined the functions

By
I. BOSINOFF
A. C. LUTHER
F. W. MILLSPAUGH
H. M. POTTER

Broadcast Studio Engineering

of several previously required units and has cut in half the number of external power supplies required, resulting in a TK-41 Camera Chain with only $1\frac{1}{3}$ racks of equipment. Likewise, a minimum number of tubes are required (125 less) and power requirements have been kept to a minimum (50 per cent less).

It is called a processing amplifier since it incorporates the majority of signal processing functions of the camera chain. Its high degree of stability, efficiency and compactness, because of its completely new and

advanced circuitry, is unique. This high stability plus a newly developed semi-automatic setup procedure offers savings in operation costs which result from reduction of setup time.

Design and Use

Figure 2 shows the processing amplifier in a console mounting. Provisions in the mounting design make it equally adaptable to rack type mounting if desired. (Fig. 3.)

The processing amplifier is an equipment of an entirely new design and represents a radical departure from all conventional circuitry used in the past to perform these functions. The basic circuit elements are three plug-in video amplifiers (Fig. 4) which very accurately and with extreme stability perform the functions of cable compensation, video amplification, blank-

FIG. 1. RCA processing amplifier is used as control equipment for RCA live color camera, TK-41, and the RCA 3-vidicon film camera, TK-26.



FIG. 2. The processing amplifier in its console housing. This is used in majority of installations.

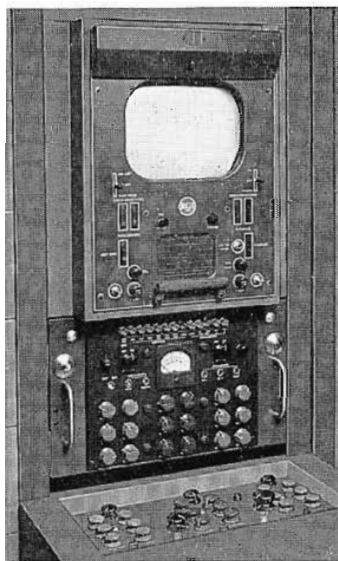

FIG. 3. Special rack mounting facilities are also available if it is desired to operate the equipment from a rack location.

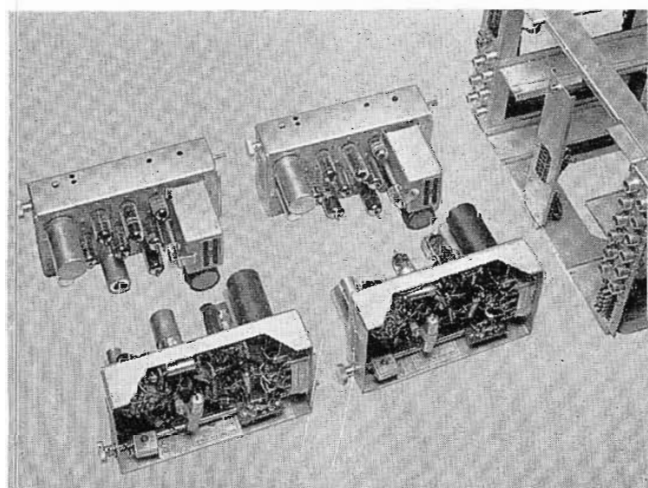

FIG. 4. The basic circuit elements of the processing amplifier are shown here—3 plug-in video amplifiers and a plug-in video section for an electronic switcher.

ing insertion, shading insertion, feedback clamping, linear clipping, gamma correction and output amplification. The pulse circuitry required for the plug-in video amplifiers, as well as the horizontal and vertical drive pulses for the camera and the shading generator, utilize stabilized multivibrators to provide pulses of constant amplitude and width independent of the amplitude and width of the incoming pulses. Shading signal generators are provided for the insertion of either horizontal or vertical axis shading. A fourth plug-in unit identical with the red, blue, and green serves as the video section of an electronic switcher. The switching circuitry of the electronic switcher is located on one of the two main chassis sections. This switcher in conjunction with a TM-6C master monitor will provide a sequential presentation of the red, blue, and green video information.

Because of the limited scope of this article it is not feasible to describe in detail all of the circuitry that performs the foregoing functions. However, in order to illustrate the overall design philosophy followed, a limited number of items are discussed in some detail.

From a system viewpoint it was thought desirable to incorporate the following items:

- (1) Centralization of all the control equipment,
- (2) Semi-automatic calibration of the monitoring facilities that provide easy, accurate and rapid setup of the complete camera chain,
- (3) A substantial increase in the simplicity

of the system resulting in improved reliability and operating efficiency,

- (4) Stabilized circuitry.

Gain control philosophy is discussed here as an illustration of some of the techniques which lead to control and setup simplification. Gain controls are required in a color camera for the following reasons:

- (1) Set up all parts of the system to prevent any possible overload due to large video signal,
- (2) Provide operational gain controls for final color balance and trimming of the system,
- (3) Provide adjustment of the monitoring facilities so that accurate video measurements may be made,
- (4) Provide adjustments for points in the system where video levels must be standardized such as across the gamma network or the output of the processing amplifier.

A block diagram to illustrate the above is shown in Fig. 5. Note how the gain problem is solved from the standpoint of stability, ease of operation, and reliability. Particular care has been taken to eliminate the possibility of any ambiguity in the adjustment of the gain controls.

Note the first gain control is the dynode gain control of the image orthicons. The reason for this set up control is that different image orthicons have different multiplier gains; and in order that the preamplifier not overload (i.e. maintain linearity), it is desirable to control the video level at the preamplifier input. However,

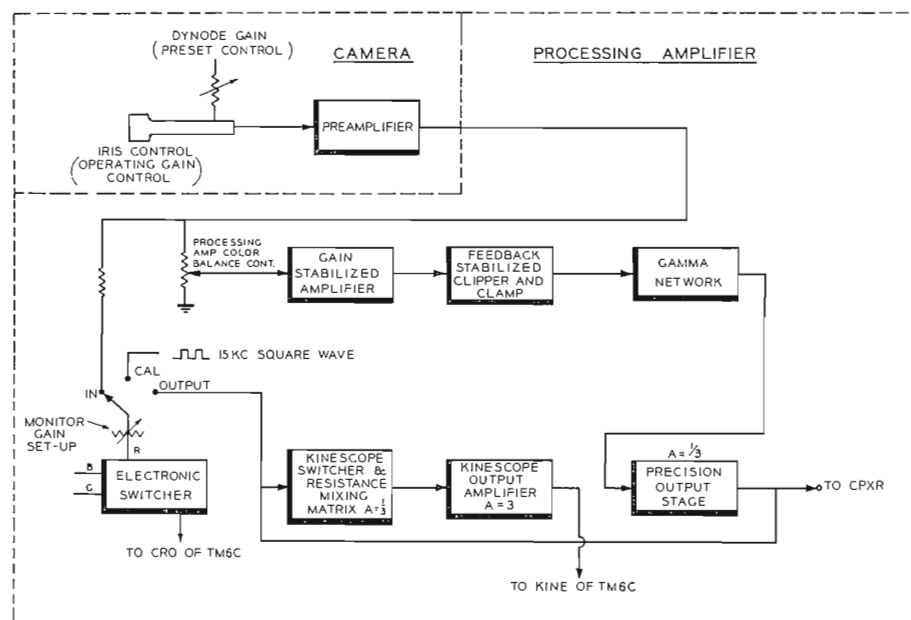

FIG. 5. A block diagram showing the gain control function incorporated in the processing amplifier.

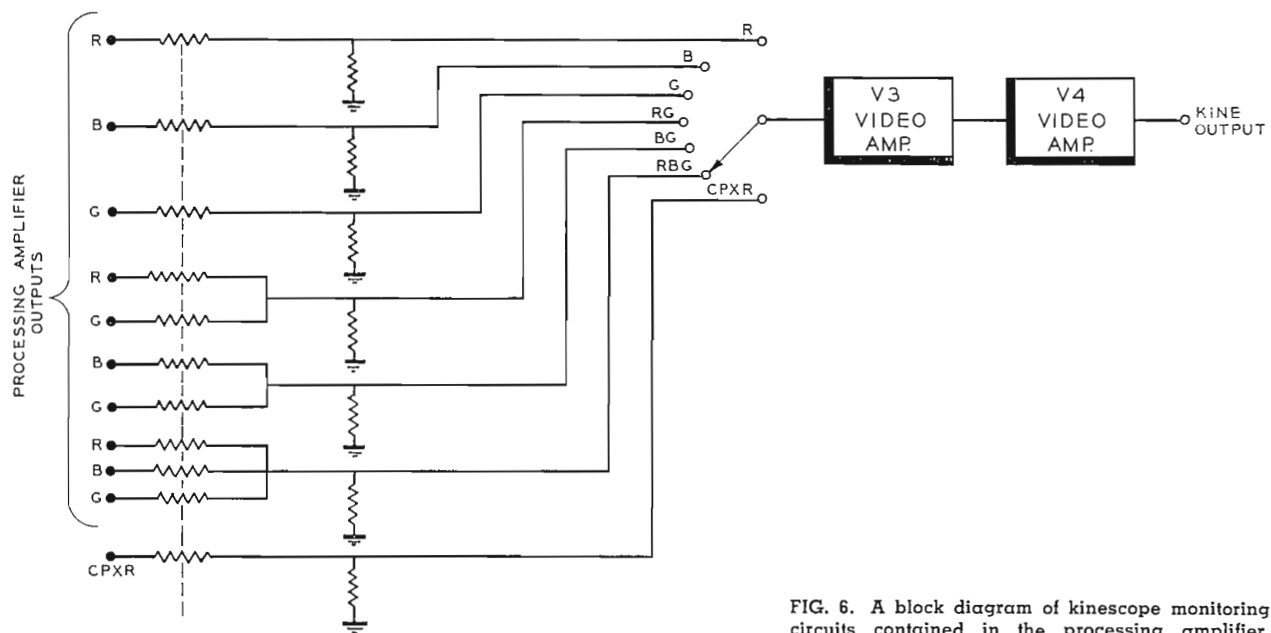

FIG. 6. A block diagram of kinescope monitoring circuits contained in the processing amplifier.

the level should not be reduced so low that the signal on the camera cable is small compared to the hum and noise level of the cable. A signal level of 0.3 volts peak-to-peak at the preamplifier output has been found satisfactory, and a monitoring position has been provided on the processing amplifier so that this approximate video level may be maintained in the camera cable. However, this is not the balance control because it is non-linear and does not provide vernier adjustment; also the dynode gain control would require additional high voltage wires within the camera cable. The balance control is a low impedance potentiometer at the input of the processing amplifier. This type of gain control is linear, and its response is instantaneous. Also, there is no transient disturbance, no matter how rapidly the control is varied. The actual operating gain control for both image orthicon or 3-V system is a master light control.

A number of gain controls are eliminated by using bridging monitoring circuits and thus eliminating isolation amplifiers with their attendant gain calibration problems. The kinescope monitoring circuits are shown in Fig. 6. This satisfies the condition that the video signal to the kinescope grid remains essentially constant for all positions of the monitor switch. Since all monitoring is bridging, a direct calibration scheme can be used to advantage. The only requirement that must be met is that there be sufficient isolation, so that operation of the monitoring switcher causes no visible disturbances in the outgoing lines. This condition has been met in the processing amplifier.

Black Level Stability

Black level stability has always been an important factor in the design of television pickup equipment. The need for a constant picture black level in the presence of vary-

ing picture content originally prompted the development of d-c restorers and keyed clamp circuits. Blanking insertion in the camera amplifiers in the past was set up on the basis of these types of black level setters. However, little attention has previously been directed toward maintaining the circuit adjustment over long periods of time, since in normal monochrome television operation, the black level is subject to considerable manual correction to obtain the desired picture effects.

Color television has caused the black level problem to be considered in a new light. In such a system there is only one correct value of black level for each pickup device which will produce overall color balance and proper gamma. In color it is not practical to ride individual pedestal controls during programming. Consequently stable black level circuitry has been developed for the processing amplifier to the

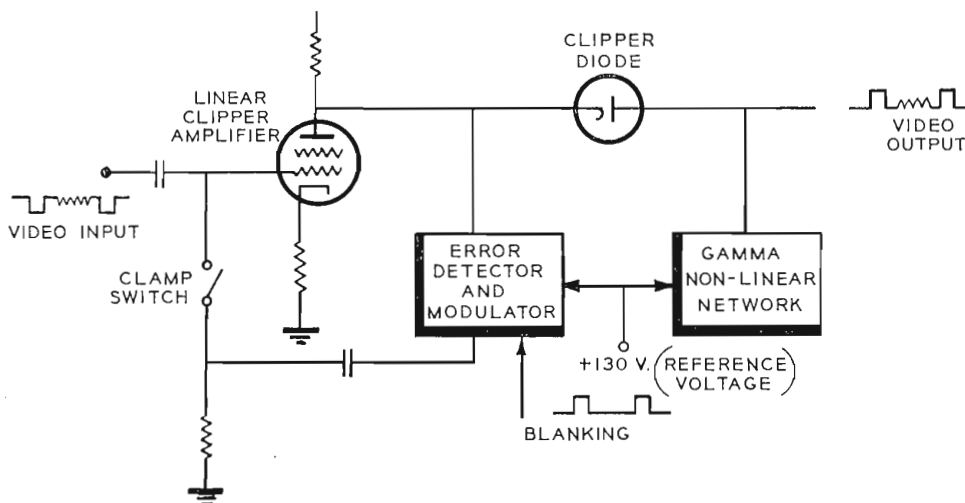

FIG. 7. A block diagram of feedback clamp circuit.

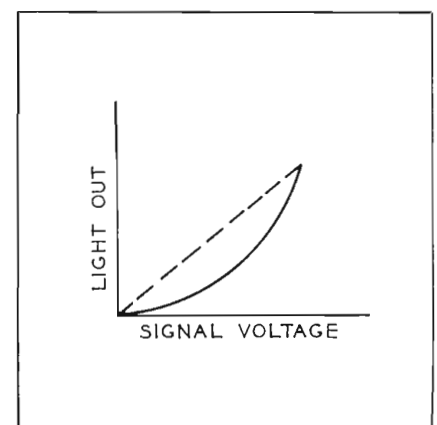

FIG. 8. Transfer curve of an average kinescope.

extent that once set up no compensation will be required for equipment drift to maintain proper color balance and gamma over the usual operating interval.

Feedback Clamping

A simplified block diagram showing the feedback clamp circuit used in the processing amplifier is shown in Fig. 7.

In the feedback clamper, the error signal is developed by measuring the level of the blanking interval on the signal going into the video clipper. This signal is compared to the level at which the clipper cuts off, so that the difference is fed back to adjust the clipper. In this manner, the cutoff of the clipper may be held at black level independent of d-c drift of the intervening amplifiers.

Since the error signal must be measured in the plate circuit of the clipper amplifier as shown in Fig. 7 and then inserted by adjusting the return voltage of a conventional clamp circuit at the grid of the same amplifier, some means is necessary to change the d-c level of the error from +130 down to approximately ground level to make such a feedback loop possible. This is done in Fig. 7 by keying the error amplifier with blanking so that the error signal comes out as a negative pulse, whose amplitude contains the error information. Since the clamp circuit conducts only during the blanking pulse, it sees only the negative part of the error pulse. The clamp capacitor receives a d-c charge which depends on the amplitude of the error pulse, thus it is sufficient to a-c couple the error signal to ground level, making it suitable for insertion in the grid circuit.

Gamma

The gamma circuit is a non-linear device which is used to compensate for the non-linear characteristic of the kinescope in the home receiver. The average kinescope has a transfer curve similar to that shown in Fig. 8. It will be noted from the trans-

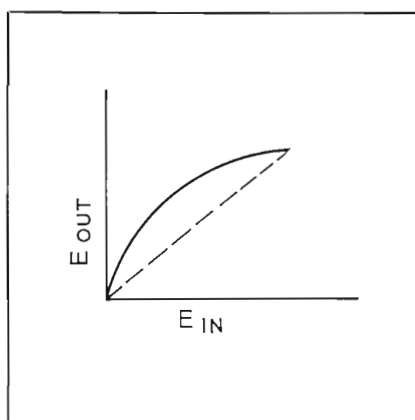

FIG. 9. Transfer curve of the television camera system.

fer curve that variations in small signals near black level do not cause as great a change in light output as proportional changes in signals near white level. Thus the kinescope tends to compress the signals at lowlights and stretch the signals at high-lights. The television camera system must have a transfer characteristic which is the inverse of the average color kinescope as shown in Fig. 9. This curve is approximately a $1/2.2$ power. Since the image orthicon itself (or vidicon) has a gamma of 0.65 the non-linear impedance must have a characteristic of 0.7 to achieve this overall camera gamma characteristic of $1/2.2$.

black level is exactly related to the blanking level zero current condition in the diode clipper load resistor. Thus black level can be automatically set on this impedance by the simple expedient of properly setting the pedestal.

An additional requirement on the gamma circuit is that the peak-to-peak video level be accurately determined across the non-linear impedance. Since the operator normally controls the video level by observing the output of the processing amplifier, this level can be accurately determined by having a precision amplifier between the gamma impedance and the output.

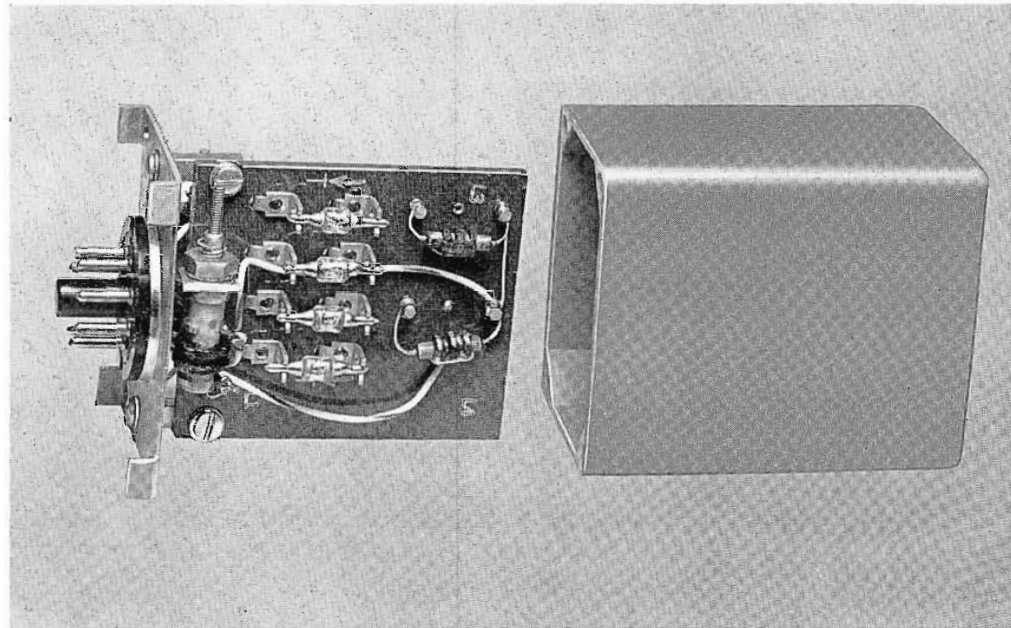

FIG. 10. The non-linear impedance network is a plug-in unit.

The circuit performs this non-linear function by amplifying at low levels more than at high levels. This is often referred to as "stretching the black" or "compressing the whites".

The particular circuit developed for performing this function is unique in that it has no adjustable controls, the complete transfer characteristic being fixed by using precision components.

Stability of the gamma operation is achieved by placing the non-linear impedance at a point in the system where black level inherently corresponds to zero voltage across this impedance. This is the situation that exists at the load impedance of the diode linear clipper circuit. Blanking forces the diode to cut off during the blanking interval. Thus when the operator has adjusted the pedestal control so that picture black level corresponds to blanking level, or slightly higher if set up is being used,

Figure 7 shows location of the gamma network. This non-linear impedance is made plug-in so that the transfer characteristic may be readily changed. A photograph of the non-linear impedance network is shown in Fig. 10.

Figure 11 shows how transfer characteristic is synthesized with diodes and associated resistors. The level across the network is high enough and the impedance in series with each diode is high enough so that the individual diode characteristics become negligible. Bias for each diode is provided by the current bled through the series resistor; this bias is the exact amount required as shown by e_2 and e_3 in Fig. 11 since black level corresponds to zero current and there is no initial black current to overcome. Measurements on this 0.7 gamma circuit have shown that with all manufacturing tolerances, voltage tolerances, and gain tolerances, if the gain and

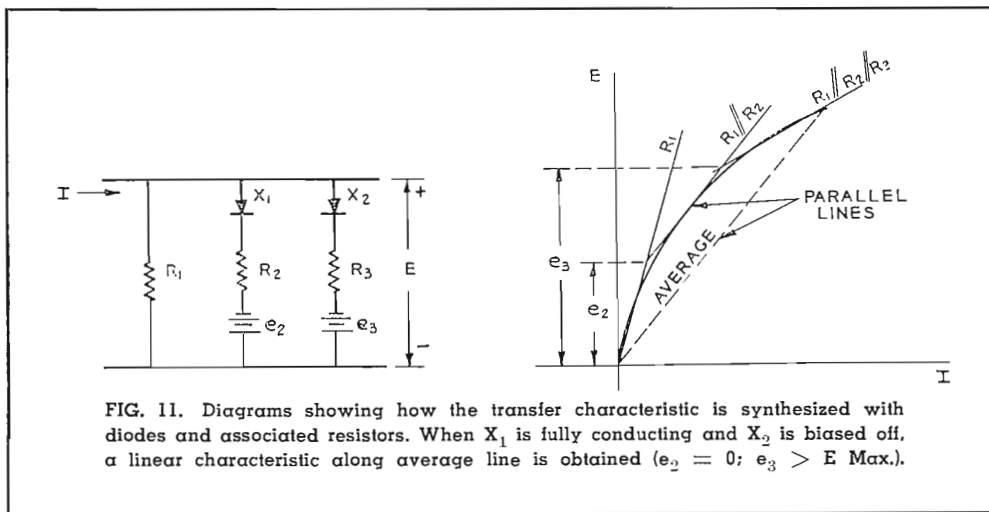

FIG. 11. Diagrams showing how the transfer characteristic is synthesized with diodes and associated resistors. When X_1 is fully conducting and X_2 is biased off, a linear characteristic along average line is obtained ($e_2 = 0$; $e_3 > E \text{ Max.}$).

pedestal have been properly set by observing the output signal, the gamma will be within 1 per cent.

The circuit of Fig. 11 is designed so that gamma can be electronically switched out for camera measurements requiring a linear amplifier, without changing the overall gain. One of the segments of the non-linear synthesis curve is arbitrarily made parallel to the average slope of the gamma curve. Thus the diode biases may be switched so that operation is all on the second curve

segment which has the correct slope to give the same maximum signal output as when gamma is in. This is achieved by making $e_2 = 0$ and $e_3 > \text{maximum signal}$.

Pulse Circuits

All of the pulse inputs required for the operation of the camera chain are high impedance loop-through connections. Thus it is possible to operate a number of color camera chains without the need of any auxiliary pulse distribution amplifiers. In the case of horizontal and vertical drive,

the pulses are actually regenerated in stabilized multivibrators so that the outgoing pulses are independent of the width and amplitude of the incoming pulses.

An adjustable clamp pulse delay circuit is available so that camera cables up to 1000 feet in length can be accommodated.

Shading Circuits

Simple and efficient shading circuits are available that provide additive shading, both parabola and sawtooth, for the red, blue, and green channels. The horizontal shading circuit involves only half of a dual triode. A horizontal pulse of large amplitude is integrated once to form a sawtooth and then integrated a second time to form a parabola. The vertical shading voltages are generated in a similar manner, but since they cannot be added to the video signal ahead of the clamp circuits they must be amplified and then added to the video signal at a later point in the system. Provision is also made for using the shading signals in conjunction with the modulation shading unit for 3-V color film pickup operation.

Operation of Electronic Switcher

It is the function of the electronic switcher to provide a side by side display of the red, blue, and green video informa-

FIG. 12. Block diagram showing the monitoring circuits of the RCA processing amplifier.

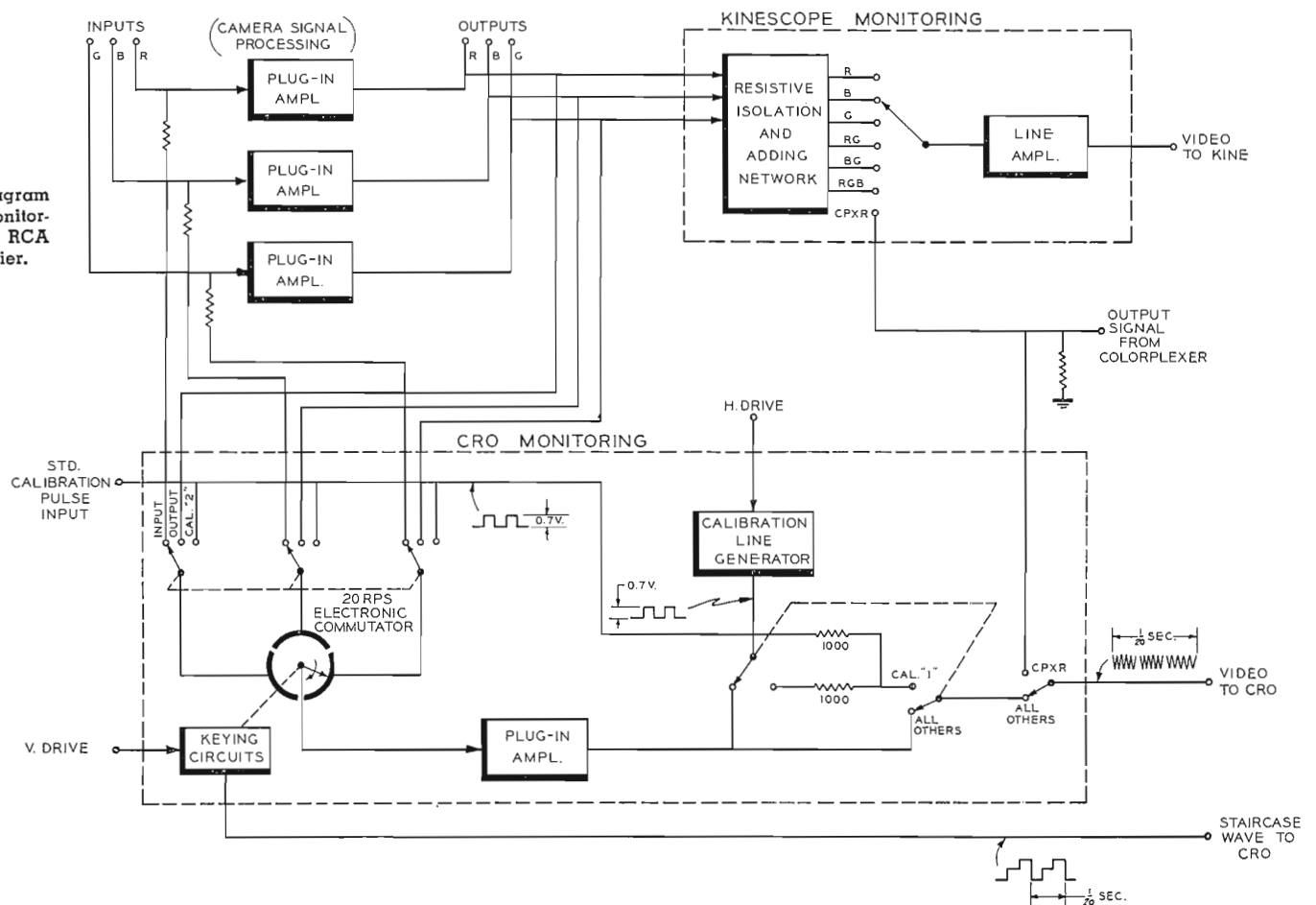

tion on the CRO of a TM-6C master monitor. This enables the video operator to simultaneously monitor all of the video inputs to the colorplexers and then properly operate the gain and pedestal controls which are the only operating controls of the camera chain used during programming. The switching circuits delivering signals to the kinescope and the oscilloscope of the TM-6C master monitor are shown in the block diagram, Fig. 12. A close-up of the pushbuttons of the electronic switcher is shown in Fig. 13. Seven signals may be viewed on the kinescope. The first six of these are the single color channel signals and their combinations, which are used for individual camera tube setup and registration. In addition, the output signal from the colorplexer may be viewed. In operation, this output is normally selected, since it provides the on-air picture. Resistive isolation of the various kinescope monitoring points eliminates crosstalk and prevents switching transients from appearing on the outgoing lines.

The oscilloscope switching circuits are somewhat more complicated, principally because they must show red, blue, and green video waveform displays simultaneously. This is accomplished by electronically switching the CRO input at a 20-cycle rate to present sequentially one field each of the red, blue, and green video waveforms. A step waveform is added to the normal sawtooth horizontal sweep of the oscilloscope to display the three signals in side-by-side fashion. This display is shown by Fig. 14. Note that the oscilloscope sweep may be switched to either a single line or single field display, but that the switching from one color to the next always occurs at field rate. Since the switching is done at a relatively slow rate, any transients generated by the switching circuits are readily removed by clamping. This and other cleaning up operations are performed in the electronic switcher plug-in amplifier.

In order to eliminate parallax in matching video levels on the side-by-side display, an electronic calibration line is introduced into the pattern by adding an accurately clipped pulse to the output of the plug-in amplifier. This appears as a thin line at the top of the vertical-frequency display as seen in Fig. 14.

The input of the electronic switcher is provided with a pushbutton switch having five positions which can select either the input or the output of the three color channel plug-in amplifiers, two calibration positions, or the colorplexer output. In this last case, the signal does not pass through the electronic commutator or the plug-in

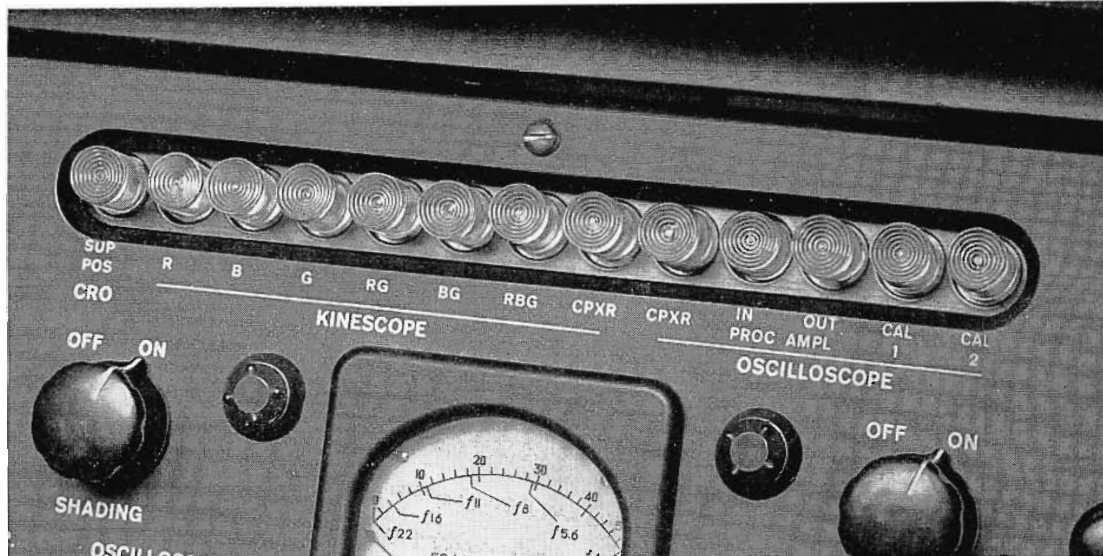

FIG. 13. Close-up of the push buttons of the electronic switcher.

amplifier, but is switched directly to the CRO input. This is necessary because the electronic switcher amplifiers do not have adequate characteristics for accurate presentation of the composite color signal, and they chop out the blanking interval which would make it impossible to see the color sync burst or the sync pulse if present. This presentation is shown in Fig. 15 (top).

The two calibration positions of the CRO selector switch make use of an external 15,750 cycle square wave from a WA-9A Calibration Pulse Generator. This same signal is looped through all processing amplifiers in a studio so that all use the same standard calibration signal. On the first position, the calibration signal is added to the pulse for the electronic calibration line and viewed on the CRO. See Fig. 15 (bottom). Since these pulses do not coincide in time, it is very easy to adjust the calibration line so that it is the same amplitude as the standard square wave. On a vertical-frequency display, two horizontal lines are seen on the scope; these are simply adjusted

for coincidence. Similarly, on the second calibration position, the square wave is connected to all three inputs of the electronic switcher. The gain of each channel of the switcher is then adjusted so that the output square wave is equal in amplitude to the calibration line. These two simple steps serve to calibrate all of the CRO monitoring functions in the processing amplifier and provide accurate balance between the wave-form monitoring system of several camera chains in the same studio.

Summary

Design and development of the RCA processing amplifier has both simplified and standardized control operations for color television. Its compact design has incorporated many new techniques to provide (1) centralization of all control equipment, (2) easy, accurate, and rapid setup of camera chains, (3) system simplicity and maximum reliability and (4) extra stable circuitry. Its use in both RCA Live Camera and Film Camera Chains results in economical and straightforward operation.

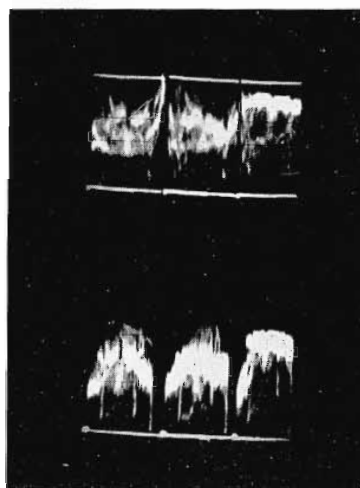

FIG. 14. Above: Sequential display of red, blue and green video signals in a vertical presentation showing the electronic calibration line. Below: Horizontal display with the calibration line out.

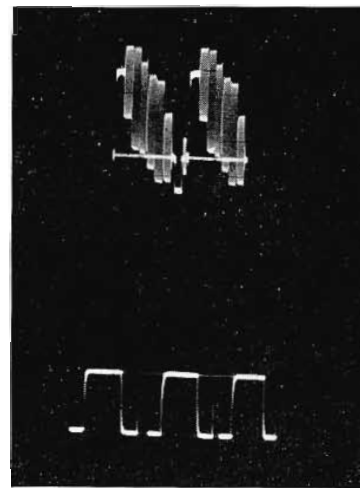

FIG. 15. Above: Colorplexer output signal for a color bar test pattern displayed at half-horizontal frequencies. Below: Typical display showing calibrating square wave with electronic calibration lines superimposed in the background.

RCA AMPLI

RCA *Ampliphase* RCA

**50-KW AM
AIR COOLED!**

**New RCA 50-kilowatt
AM Transmitter BTA-50G**

**DESIGNED WITH
AMPLIPHASE MODULATION**

HOW IT WORKS!

To produce phase-to-amplitude modulation in the BTA-50G, a carrier wave is developed by a common exciter. This carrier wave is then split and fed through phase-shift networks that establish a carrier phase difference. These two signals are controlled so that each maintains a prescribed phase relationship with the other in accordance with the intensity of modulating signal. This controlled phase relationship enables the separate 25-kilowatt amplifiers, when feeding their outputs into a combining circuit, to produce a maximum level 50-kilowatt amplitude modulated signal.

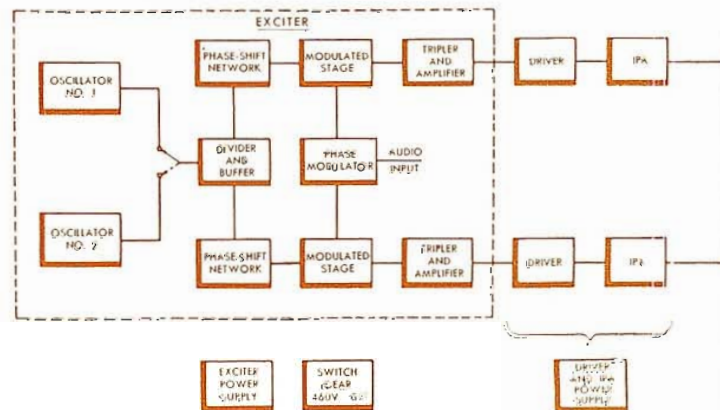

SIMPLIFIED BLOCK DIAGRAM—BTA-50G TRANSMITTER

PHASE

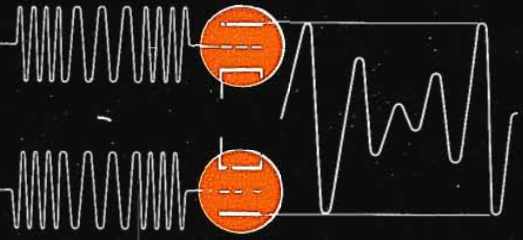

A new concept in AM Broadcasting!

*... introduced in RCA's revolutionary
new 50-KW AM transmitter*

Here is the most significant forward step in AM transmitters since RCA introduced high level modulation—an entirely new 50-KW transmitter using Ampliphase Modulation. Newest and finest in RCA's long line of distinguished AM transmitter designs, it is further proof of RCA leadership in the broadcast equipment field.

Ampliphase cuts transmitter floor space and operating costs by substantial margins. The BTA-50G is housed in four cubicles. It does away with half of present power tubes . . . along with bulky components such as modulation transformers,

reactors and accessories. It requires no underfloor trenches, costly water cooling systems, external blowers. And there's no lost air-time—because the 50-KW Ampliphase is remarkably easy to install while your present transmitter is in operation. Then, in most cases, you may keep your old unit as a stand-by.

For complete technical details . . . and for information on the surprisingly low price . . . call your RCA Broadcast Sales Representative. In Canada, write RCA VICTOR Company Limited, Montreal.

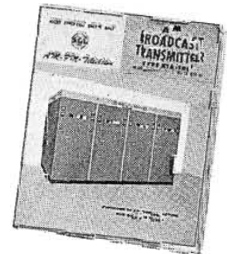

FACTS ABOUT RCA'S NEW 50-KW AM

- Takes less than 80 square feet of floor space. No underfloor trenches required.
- Lowest operating cost of any 50-KW AM transmitter.
- Half the tube cost of other 50-KW AM transmitters.
- Uses famous Long-Life RCA 5671 P.A. tubes.
- No Modulation transformer required.
- Completely air-cooled with internal blowers—no air intake ducts necessary.
- Low distortion, excellent frequency response.
- Splatter-free modulation provided by new Ampliphase design.
- Designed to permit remote-control operation.
- New simplified circuitry. Extremely stable operation.

PIONEERS IN AM BROADCASTING FOR OVER 25 YEARS



RADIO CORPORATION of AMERICA
ENGINEERING PRODUCTS DIVISION

CAMDEN, N.J.

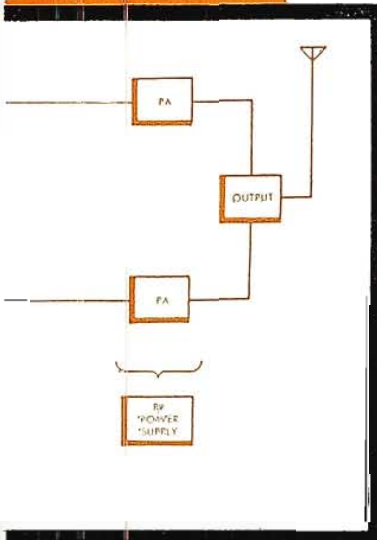

NEW...

RCA

All New Type

10,000 WATTS



With High Quality Sound Channel

*Good Color
Performance
Depends on These
Specifications*

- Power Output . . . 1 Watt, Nominal.
- Differential Gain (Linearity) . . . 0.5 db max.
- Differential Phase Distortion (at 3.58 mc) . . . less than 1%.
- Amplitude Frequency Response . . . Flat within 0.5 db 60 cycles to 6 mc.
- Synchronizing Signal Compression . . . Negligible.
- Low Frequency Square Wave Response . . . Less than 1% tilt at 60 cycles.

For descriptive literature on this newest of microwave systems or help in planning your microwave setup, consult your RCA Broadcast Sales Representative.

MICROWAVE

High-Power

TVM-1A designed for Color TV

(Best for Monochrome, too)

ERP AT 7000 MC

The TVM-1A is the only microwave equipment designed specifically as an integral part of a complete color TV system . . . from color originating equipment to color receivers. Whether you're a monochrome or color user, you will appreciate these special advantages:

HIGH POWER

An increase of 10 in transmitter power and about 3 db in receiver sensitivity offers 20 times the power margin of the popular RCA TTR-TRR series of microwave equipment. This means greater operational reliability with an increased fading margin.

SOUND DIPLEXING

Included in the TVM-1A system is high quality audio channel for the simultaneous transmission of sound along with picture

information. This sound channel is well within FCC requirements for a studio-to-transmitter link (STL).

TRANSMITTER AUTOMATIC FREQUENCY CONTROL

Transmitter AFC offers exceptionally good frequency response and highest stability. It is especially useful in multihop operation with unattended repeater stations.

TRANSMITTER PICTURE MONITORING

This facility assures an actual high quality "air" signal. It simplifies trouble shooting procedures and is also extremely useful in the operation of unattended repeater stations.

RCA Pioneered and Developed Compatible Color Television



RADIO CORPORATION of AMERICA
ENGINEERING PRODUCTS DIVISION

CAMDEN, N.J.

For Export . . .

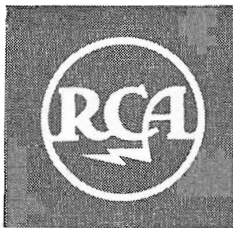

RCA's new design sets Tomorrow's standard for radio telegraph transmitters

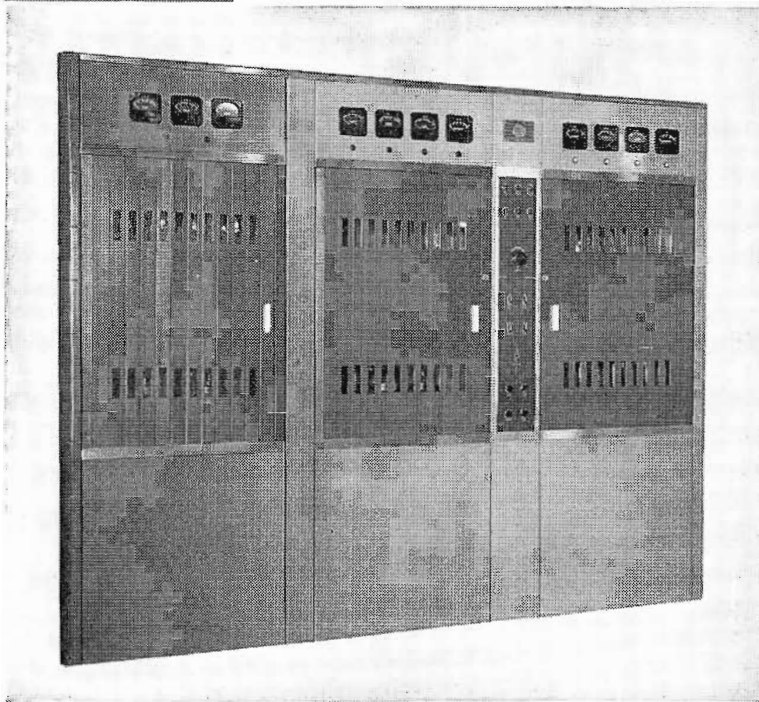

★ **SAVE MONEY** on personnel training — extremely simple to operate.

★ **SAVE MONEY** on installation — self-contained, factory-wired unit.** Occupies smallest possible space. Building alterations unnecessary.

★ **SAVE MONEY** on operation. Tube, power and depreciation costs are extremely low.

NEW RCA ET-18 15KW radiotelegraph transmitter uses latest multigrad tubes for self-neutralization. Ideal harmonic suppression (no interference with TV or other signals); exceptional circuit stability.

Revolutionary Advance in Frequency-Shift Telegraphy—RCA's years-ahead ET-18 15KW transmitter—efficient, reliable, versatile. A modulator is available to convert it for 10KW broadcasting, AM telephony, or single sideband telephone and telegraph transmission. The ET-18 provides full power output over the entire 3.2 to 24 mc range. There are only three radio-frequency power stages between the 2-watt frequency-shift keyer and full power output; and all power amplification is at operating frequency.

****Lowest cost.** Self-contained and factory-

wired except for one external power transformer, the entire unit occupies only 25.8 sq. ft. of floor space—may be located in existing building without expensive alterations. With minimum instruction, non-technical personnel can operate the ET-18. It requires attention only when frequency is to be changed. And the total number of components has been decreased, reducing your replacement problems. Difficult-to-service mechanisms have been eliminated.

As a long-range investment, the ET-18 has no peer. For complete information, see your RCA distributor or write:

MARCA(S) REGISTRADA(S)
TRADEMARK(S) REGISTERED



RCA INTERNATIONAL DIVISION

RADIO CORPORATION of AMERICA

RCA BUILDING

30 ROCKEFELLER PLAZA, NEW YORK N. Y., U. S. A.

NOW-11 KW

...with RCA's TT-10AL

for VHF

With recent design advances, RCA engineers have increased the power output of the TT-10AL VHF transmitter. This popular transmitter now delivers a full 11 KW of peak visual power (low band)—measured at the output of the sideband filter. If you need this extra KW, it's yours now.

Costs no more than the original 10-KW design—and of course it can handle color.

With power increased to 11 KW, RCA's exclusive TT-10AL—in combination with an RCA 12-section antenna—is the most

outstanding VHF system in the industry, delivering 100 KW ERP at the lowest operating cost of any VHF equipment package now available.

RCA 11 kilowatters are ready to ship. Order yours now for early delivery. For complete details, see your RCA Broadcast Sales Representative. In Canada, write RCA VICTOR Company Ltd., Montreal.

Ask your Broadcast Sales Representative for literature describing RCA's new 11-KW design for channels 2 to 6.

RCA Pioneered and Developed Compatible Color Television



RADIO CORPORATION of AMERICA
ENGINEERING PRODUCTS DEPARTMENT
CAMDEN, N. J.

STAR PERFORMER

... year
after
year

This is the Image Orthicon, Type 5820. RCA designed this tube — and developed the specialized equipment and techniques necessary to precision-manufacture it.

Known for superb picture quality, high stability, and remarkable uniformity, RCA Image

Orthicons have been making friends with TV stationmen and sponsors since 1949.

RCA-5820 Image Orthicon—
the TV Camera Tube that made
modern telecasting practicable



PICK-UP TUBES for TELECASTING

RADIO CORPORATION OF AMERICA